

10ACB SERIES UNITS

The 10ACB is a residential split-system condensing unit available in sizes ranging from 1 to 5 tons. Condensing coil size, circuiting and air volume result in a minimum SEER rating of 10.0. The series is designed for use with an expansion valve or RFCIV system in the indoor unit. However, the 10ACB60 uses only the TXV system.

10ACB model units are equipped with either a reciprocating compressor or a scroll compressor. All compressors are hermetically sealed for long service life. The compressor is installed in the unit on resilient rubber mounts to assure quiet, vibration-free operation. A built-in protection device assures protection from excessive current and temperatures. The scroll operates like a standard compressor but it is unique in the way it compresses refrigerant.

10ACB42 through 10ACB60 models equipped with reciprocating compressors, are furnished with crankcase heaters to assure proper compressor lubrication at all times. Heaters for all other models are an option. The heater is temperature-actuated and operates only when required.

This manual is divided into sections which discuss the major components, refrigerant system, charging procedure, maintenance and operation sequence.

All specifications in this manual are subject to change.

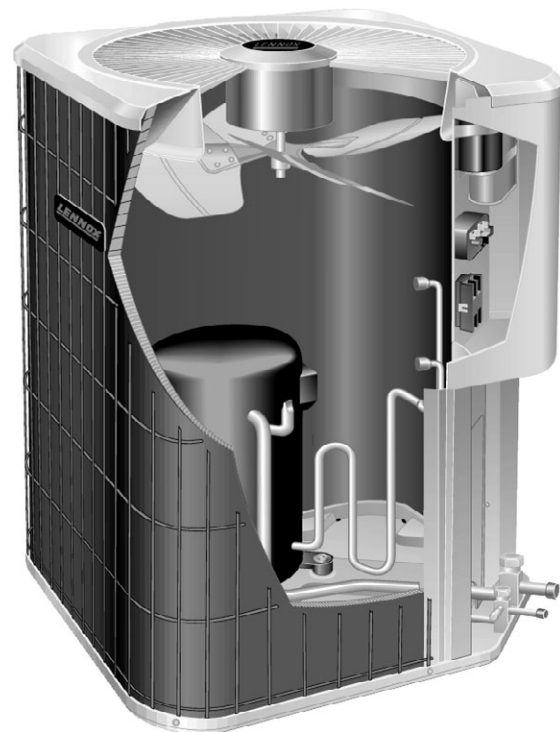

⚠ WARNING

Refrigerant can be harmful if it is inhaled. Refrigerant must be used and recovered responsibly.

Failure to follow this warning may result in personal injury or death.

⚠ WARNING



Electric shock hazard. Can cause injury or death. Before attempting to perform any service or maintenance, turn the electrical power to unit OFF at disconnect switch(es). Unit may have multiple power supplies.

⚠ IMPORTANT

Improper installation, adjustment, alteration, service or maintenance can cause property damage, personal injury or loss of life. Installation and service must be performed by a qualified installer or service agency.

**ELECTRICAL DATA
RECIPROCATING COMPRESSORS**

Model No.		10ACB12 -1 thru -10	10ACB18 -1 thru -10	10ACB24 -1 thru -10	10ACB30 -1 thru -10	10ACB36 -1 thru -11	10ACB42 -1 thru -10	10ACB48 -1 thru -9	10ACB60 -1 thru -9
Line voltage data — 60 hz - 1 phase		208/230v							
Compressor	Rated load amps	4.9	7.9	10.1	11.3	16.2	17.5	23.4	26.9
	Power factor	.97		.96	.92	.90	.98	.98	.98
	Locked rotor amps	26.3	48.3	60	69.4	96	92.0	110.0	123.0
Condenser Coil Fan Motor	Full load amps	1.1						1.9	
	Locked rotor amps	1.9						4.1	
Rec. maximum fuse or circuit breaker size (amps)		15		20	25	35	40	50	60
*Minimum circuit ampacity		7.3	11.0	13.8	15.9	21.4	23.0	31.2	35.5

*Refer to National or Canadian Electrical Code manual to determine wire, fuse and disconnect size requirements.
NOTE — Extremes of operating range are plus 10% and minus 5% of line voltage.

**ELECTRICAL DATA
SCROLL COMPRESSORS**

Model No.		10ACB42-11	10ACB48-10	10ACB60-10
Line voltage data — 60 hz - 1 phase		208/230v		
Compressor	Rated load amps	17.9	21.8	25
	Power factor	.84	.80	.90
	Locked rotor amps	103	131	170
Condenser Coil Fan Motor	Full load amps	1.1	1.9	
	Locked rotor amps	1.9	4.1	
Rec. maximum fuse or circuit breaker size (amps)		40	50	60
*Minimum circuit ampacity		23.0	31.2	35.5

*Refer to National or Canadian Electrical Code manual to determine wire, fuse and disconnect size requirements.
NOTE — Extremes of operating range are plus 10% and minus 5% of line voltage.

SPECIFICATIONS

Model No.		10ACB12	10ACB18	10ACB24	10ACB30	10ACB36	
Condenser Coil	Net face area - sq. ft. (m ²)	Outer coil	7.56 (0.70)	11.41 (1.06)		15.11 (1.40)	
		Inner coil	----				
	Tube diameter - in. (mm) & no. of rows		5/16 (7.9) — 1				
	Fins per inch (m)		18 (709)			22 (866)	
Condenser Fan	Diameter — in. (mm) & no. of blades		18 (457) — 3			18 (457) — 4	
	Motor hp (W)		1/6 (124)				
	Cfm (L/s)		2400 (1135)			2520 (1190)	
	Rpm		1105			1100	
	Watts		170			200	
*Refrigerant charge furnished (HCFC-22)		2 lbs. 12 oz. (1.25 kg)	3 lbs. 10 oz. (1.64 kg)	4 lbs. 0 oz. (1.81 kg)	4 lbs. 0 oz. (1.81 kg)	5 lbs. 0 oz. (2.26 kg)	
Liquid line — in. (mm) o.d. connection (sweat)		†3/8 (9.5)				3/8 (9.5)	
Suction line — in. (mm) o.d. connection (sweat)		5/8 (15.9)			3/4 (19.1)		
Shipping weight — lbs. (kg) 1 package		146 (66)		148 (67)	150 (71)	165 (75)	
OPTIONAL ACCESSORIES - Must Be Ordered Extra							
Low Ambient Kit - for use with expansion valve systems only		LB-57113BC (24H77)					
Crankcase Heater		68887					
Timed-Off Control		LB-61378A (47J35)					
Hail Guards		17L71				17L73	
Unit Stand Off Kit		94J45					
Mounting Base		MB2-S (69J06)					
Compressor Monitor (Optional for Canada Only)		t6-1469 (45F08)					

*Refrigerant charge sufficient for 20 ft. (6.0 m) length of refrigerant lines.
†3/8 x 5/16 in. (9.5 x 7.9 mm) adaptor furnished for liquid line connection.

SPECIFICATIONS Cont.

Model No.		10ACB42	10ACB48	10ACB60	
Condenser Coil	Net face area - sq. ft. (m ²)	Outer coil	15.11 (1.40)		
		Inner coil	5.40 (0.50)	14.40 (1.34)	
	Tube diameter — in. (mm) & no. of rows		5/16 (7.9) — 1.37		
	Fins per inch (m)		22 (866)		
Condenser Fan	Diameter — in. (mm) & no. of blades		18 (457) — 4		
	Motor hp (W)		1/6 (124)	1/3 (249)	
	Cfm (L/s)		2500 (1180)	2950 (1390)	2930 (1385)
	Rpm		1100		
	Watts		200	310	
*Refrigerant charge furnished (HCFC-22)		5 lbs. 7 oz. (2.47 kg)	6 lbs. 6 oz. (2.89 kg)	8 lbs. 8 oz. (3.86 kg)	
Liquid line — in. (mm) o.d. connection (sweat)		3/8 (9.5)			
Suction line — in. (mm) o.d. connection (sweat)		7/8 (22.2)		1-1/8 (28.6)	
Shipping weight — lbs. (kg) 1 package		191 (87)	196 (89)	212 (96)	
OPTIONAL ACCESSORIES - Must Be Ordered Extra					
Low Ambient Kit - for use with expansion valve systems only		LB-57113BC (24H77)			
Crankcase Heater		90P12			
Timed-Off Control		LB-61378A (47J35)			
Hail Guards		17L73			
Unit Stand Off Kit		94J45			
Mounting Base		MB2-S (69J06)			
Compressor Monitor (Optional for Canada Only)		T6-1469 (45F08)			

*Refrigerant charge sufficient for 20 ft. (6.0 m) length of refrigerant lines.

I - UNIT INFORMATION

⚠ DANGER

Make sure all power is disconnected before beginning electrical service procedures.

10ACB condensing units are available in 1, 1-1/2, 2, 2-1/2, 3, 3-1/2, 4 and 5 ton capacities.

All major components (indoor blower and coil) must be matched according to Lennox recommendations for the compressor to be covered under warranty. Refer to the Engineering Handbook for approved system matchups. A misapplied system will cause erratic operation and can result in early compressor failure.

II - UNIT COMPONENTS

Unit components are illustrated in figure 1.

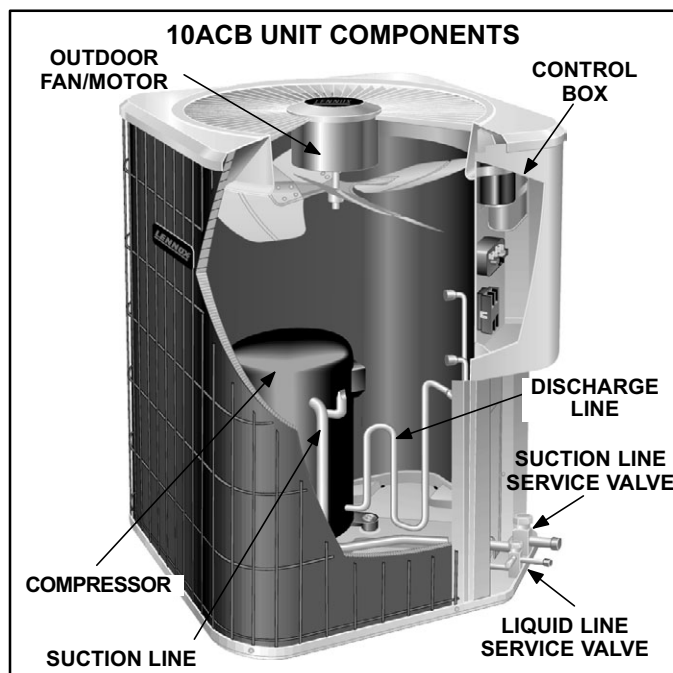

FIGURE 1

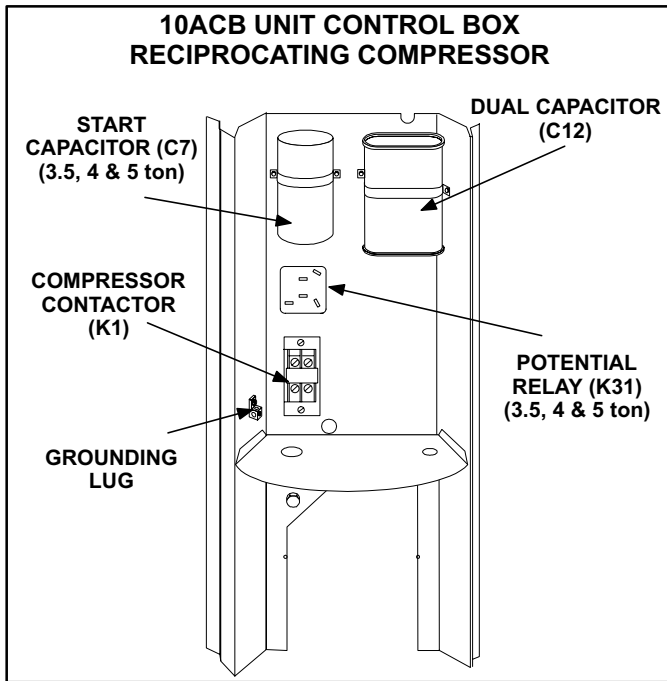

FIGURE 2

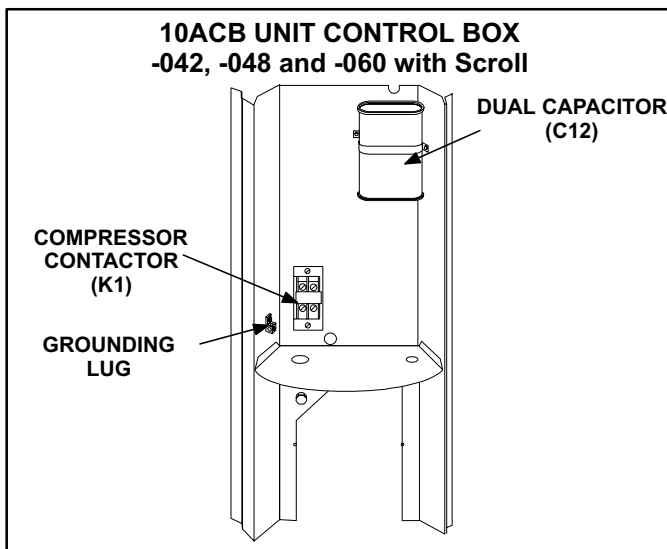

FIGURE 3

A - Control Box (Figures 2 & 3)

Electrical openings are provided under the control box cover. Field thermostat wiring is made to color-coded pigtail connections.

1 - Compressor Contactor K1

The compressor is energized by a contactor located in the control box. See figure 2. Single-pole and two-pole contactors are used in 10ACB units. See wiring diagrams for specific units. K1 is energized by the indoor thermostat terminal Y1 (24V) when thermostat demand is present.

10ACB units are not equipped with a 24V transformer. All 24 VAC controls are powered by the indoor unit. Refer to wiring diagram.

⚠ DANGER



Shock Hazard

Some 10ACB units use single-pole contactors. One leg of compressor, capacitor and condenser fan are connected to line voltage at all times. Potential exists for electrical shock resulting in injury or death. Remove all power at disconnect before servicing.

Can cause personal injury or death.

2 - Dual Capacitor C12

The compressor and fan in 10ACB series units use permanent split capacitor motors. The capacitor is located inside the unit control box (see figures 2 and 3). A single “dual” capacitor (C12) is used for both the fan motor and the compressor (see unit wiring diagram). The fan side and the compressor side of the capacitor have different MFD ratings. For ratings see side of capacitor.

3 - Start Capacitor C7

All 10ACB 3 1/2, 4 and 5 ton series units equipped with a reciprocating compressor, use a start capacitor (C7) wired in parallel with the compressor side of the dual capacitor. The capacitor is located inside the unit control box (see figure 2). C7 is switched off by potential relay (K31) when the compressor nears full speed. The start capacitor is rated at 330 VAC and has an MFD rating of 176-216.

4 - Potential (Start) Relay K31

All 10ACB 3 1/2, 4 and 5 ton series units equipped with a reciprocating compressor use a potential relay which controls the operation of the starting circuit. The potential relay is located inside the unit control box (see figure 2). The relay is normally closed when contactor K1 is de-energized. When K1 energizes, the compressor immediately begins start-up. K31 remains closed during compressor start-up and the start capacitor C7 remains in the circuit. When the compressor reaches 75% of its speed, K31 is energized. When K31 energizes, the contacts open and the start capacitor C7 is taken out of the circuit.

B - Compressor

All 10ACB units built prior to May of 1998 utilize a conventional reciprocating compressor. 10ACB-042, -048 and -060 units built after May of 1998 will be equipped with a scroll compressor. For compressor specifications see "ELECTRICAL DATA" section in this manual or the compressor nameplate.

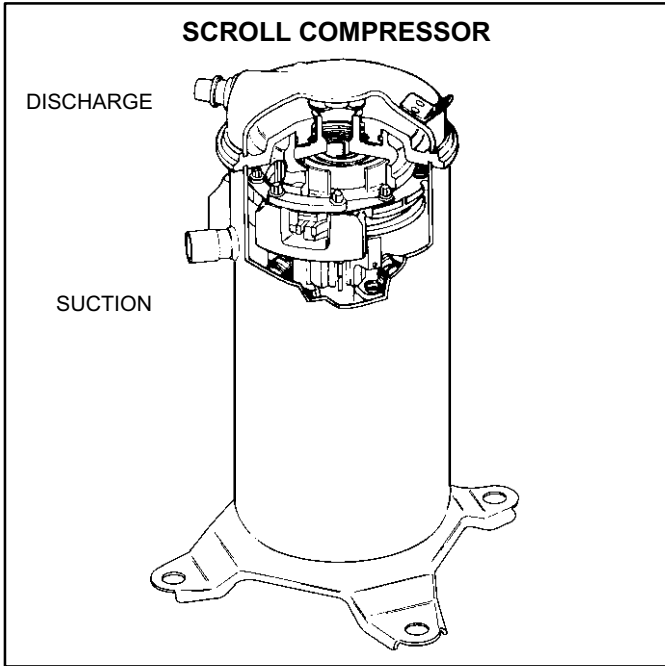

FIGURE 4

1 - Scroll Compressor

The scroll compressor design is simple, efficient and requires few moving parts. A cutaway diagram of the scroll compressor is shown in figure 4. The scrolls are located in the top of the compressor can and the motor is located just below. The oil level is immediately below the motor.

The scroll is a simple compression concept centered around the unique spiral shape of the scroll and its inherent properties. Figure 5 shows the basic scroll form. Two identical scrolls are mated together forming concentric spiral shapes (figure 6). One scroll remains stationary, while the other is allowed to "orbit" (figure 7). Note that the orbiting scroll does not rotate or turn but merely "orbits" the stationary scroll.

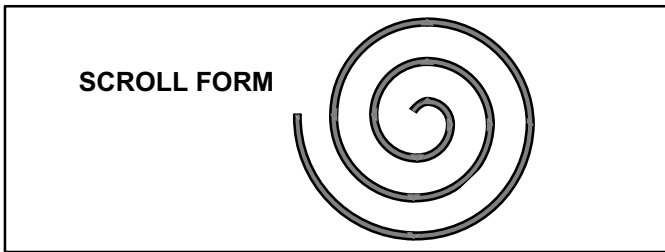

FIGURE 5

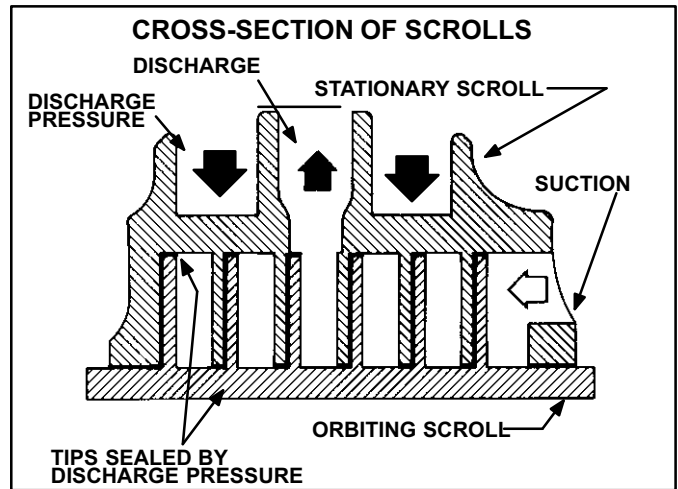

FIGURE 6

The counterclockwise orbiting scroll draws gas into the outer crescent shaped gas pocket created by the two scrolls (figure 7 - 1). The centrifugal action of the orbiting scroll seals off the flanks of the scrolls (figure 7 - 2). As the orbiting motion continues, the gas is forced toward the center of the scroll and the gas pocket becomes compressed (figure 7 - 3). When the compressed gas reaches the center, it is discharged vertically into a chamber and discharge port in the top of the compressor (figure 6). The discharge pressure forcing down on the top scroll helps seal off the upper and lower edges (tips) of the scrolls (figure 6). During a single orbit, several pockets of gas are compressed simultaneously providing smooth continuous compression.

The scroll compressor is tolerant to the effects of liquid return. If liquid enters the scrolls, the orbiting scroll is allowed to separate from the stationary scroll. The liquid is worked toward the center of the scroll and is discharged. If the compressor is replaced, conventional Lennox cleanup practices must be used.

Due to its efficiency, the scroll compressor is capable of drawing a much deeper vacuum than reciprocating compressors. Deep vacuum operation can cause internal fuse arcing resulting in damaged internal parts and will result in compressor failure. Never use a scroll compressor for evacuating or "pumping-down" the system. This type of damage can be detected and will result in denial of warranty claims.

NOTE - During operation, the head of a scroll compressor may be hot since it is in constant contact with discharge gas.

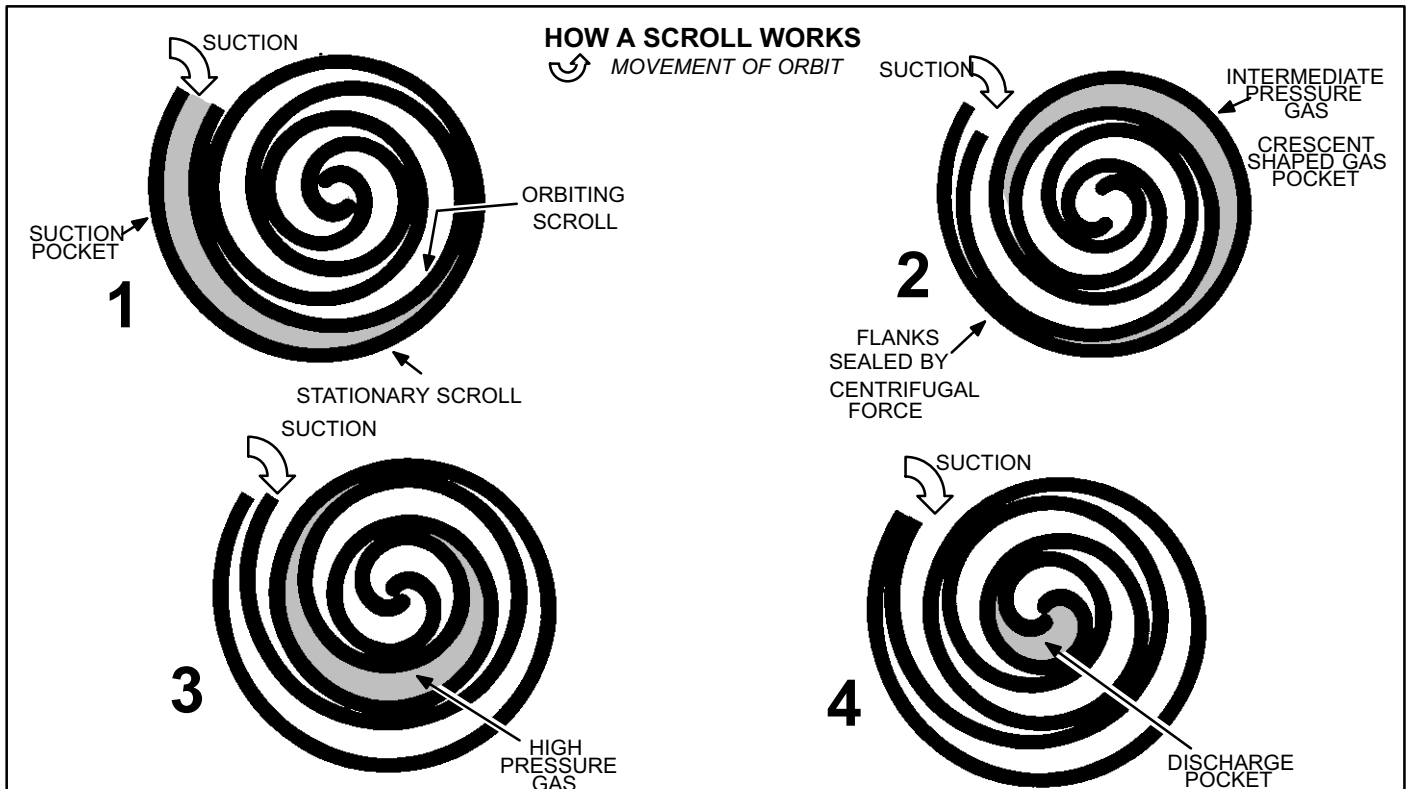

FIGURE 7

2 - Crankcase Heater

A crankcase heater is used on all 10ACB42 through 10ACB60 models equipped with a reciprocating compressor. For all other models the crankcase heater is an option and must be ordered separate. See "SPECIFICATIONS" section in this manual for part number. The well-mounted insertion-type heater is self-regulating. All heaters used on reciprocating compressors are rated at 27 watts. The heater is temperature-actuated and operates only when required.

C - Condenser Fan Motor

All units use single-phase PSC fan motors which require a run capacitor. In all units, the condenser fan is controlled by the compressor contactor.

ELECTRICAL DATA tables in this manual show specifications for condenser fans used in 10ACBs.

Access to the condenser fan motor on all units is gained by removing the seven screws securing the fan assembly. See figure 8. The condenser fan motor is removed from the fan guard by removing the four nuts found on the top panel. See figure 9 if condenser fan motor replacement is necessary.

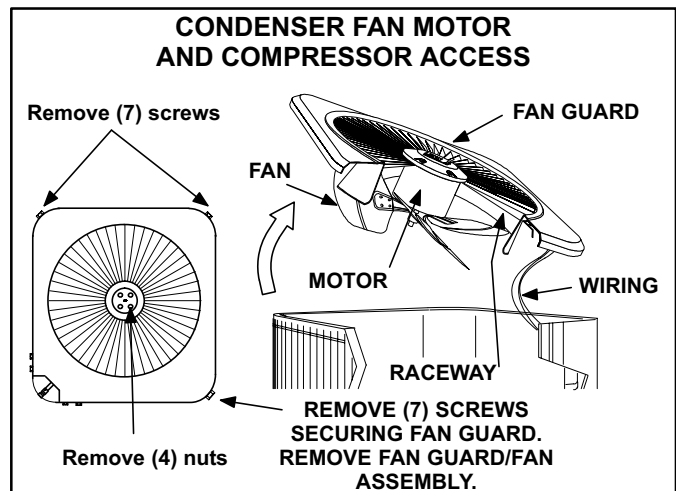

FIGURE 8

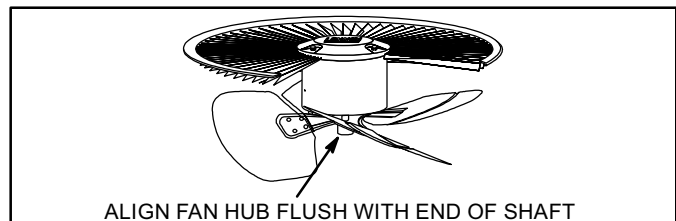

FIGURE 9

III - REFRIGERANT SYSTEM

A - Plumbing

Field refrigerant piping consists of liquid and suction lines from the condensing unit (sweat connections) to the indoor evaporator coil (flare or sweat connections). Use Lennox L10 (flare) or L15 (sweat, non-flare) series line sets as shown in table 1 or use field-fabricated refrigerant lines. Separate discharge and suction service ports are provided outside the unit for connection of gauge manifold during charging procedure.

TABLE 1

Condensing Unit Model No.	Line Set Model No. (L10 or L15)	Length of Lines		Liquid Line Outside Dia.		Suction Line Outside Dia.	
		ft.	m	in.	mm	in.	mm
10ACB12 10ACB18 10ACB24	L10/15-21-20	20	6	5/16	7.9	5/8	15.9
	L10/15-21-25	25	8				
	L10/15-21-35	35	11				
	L10/15-21-50	50	15				
10ACB30 10ACB36	L10/15-41-20	20	6	3/8	9.5	3/4	19
	L10/15-41-30	30	9				
	L10/15-41-40	40	12				
	L10/15-41-50	50	15				
10ACB42 10ACB48	L10/15-65-30	30	9	3/8	9.5	7/8	22.2
	L10/15-65-40	40	12				
	L10/15-65-50	50	15				
10ACB60	*Field fabricate		3/8	9.5	1-1/8	28.5	

*Field fabricate. See Corp. 9351-L9 Refrigerant Piping Nabual

B - Service Valves

The liquid and suction line service valves (figures 10 and 11) and gauge ports are accessible from outside the unit.

The valve is equipped with a service port. The service ports are used for leak testing, evacuating, charging and checking charge. A schrader valve is factory installed. A service port cap is supplied to protect the schrader valve from contamination and serve as the primary leak seal.

NOTE-Always keep valve stem caps clean.

To Access Schrader Port:

- 1 - Remove service port cap with an adjustable wrench.
- 2 - Connect gauge to the service port.
- 3 - When testing is completed, replace service port cap. Tighten finger tight, then an additional 1/6 turn.

To Open Liquid or Suction Line Service Valve:

- 1 - Remove stem cap with an adjustable wrench.
- 2 - Using service wrench and 5/16" hex head extension back the stem out counterclockwise until the valve stem just touches the retaining ring.
- 3 - Replace stem cap tighten firmly. Tighten finger tight, then tighten an additional 1/6 turn.

⚠ DANGER

Do not attempt to backseat this valve. Attempts to backseat this valve will cause snap ring to explode from valve body under pressure of refrigerant. Personal injury and unit damage will result.

To Close Liquid or Suction Line Service Valve:

- 1 - Remove stem cap with an adjustable wrench.
- 2 - Using service wrench and 5/16" hex head extension, turn stem clockwise to seat the valve. Tighten firmly.
- 3 - Replace stem cap. Tighten finger tight, then tighten an additional 1/6 turn.

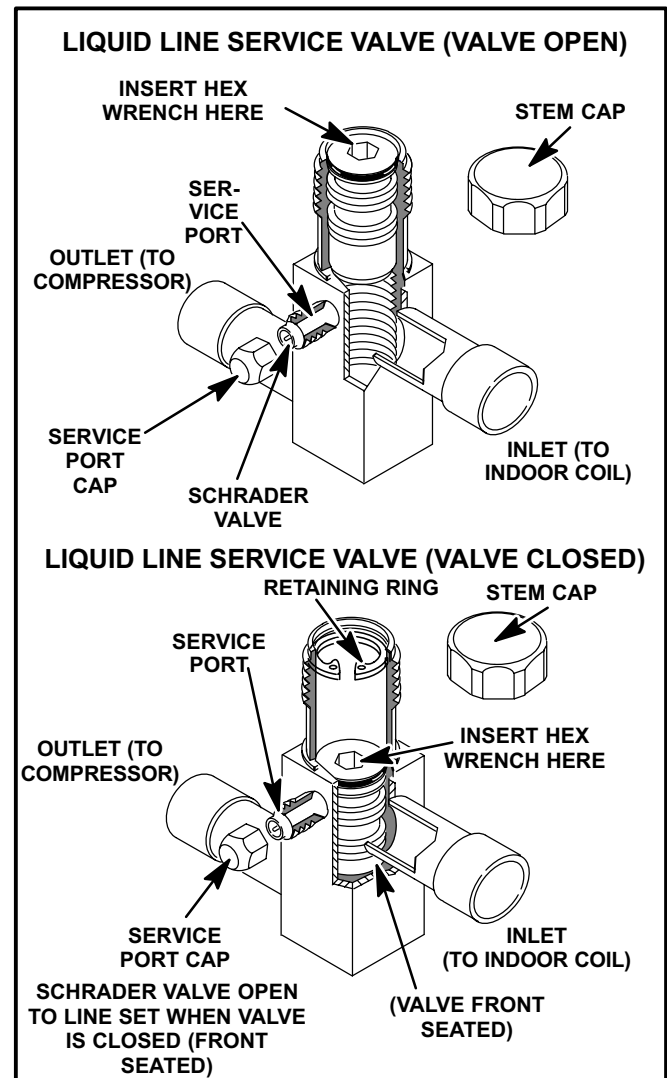

FIGURE 10

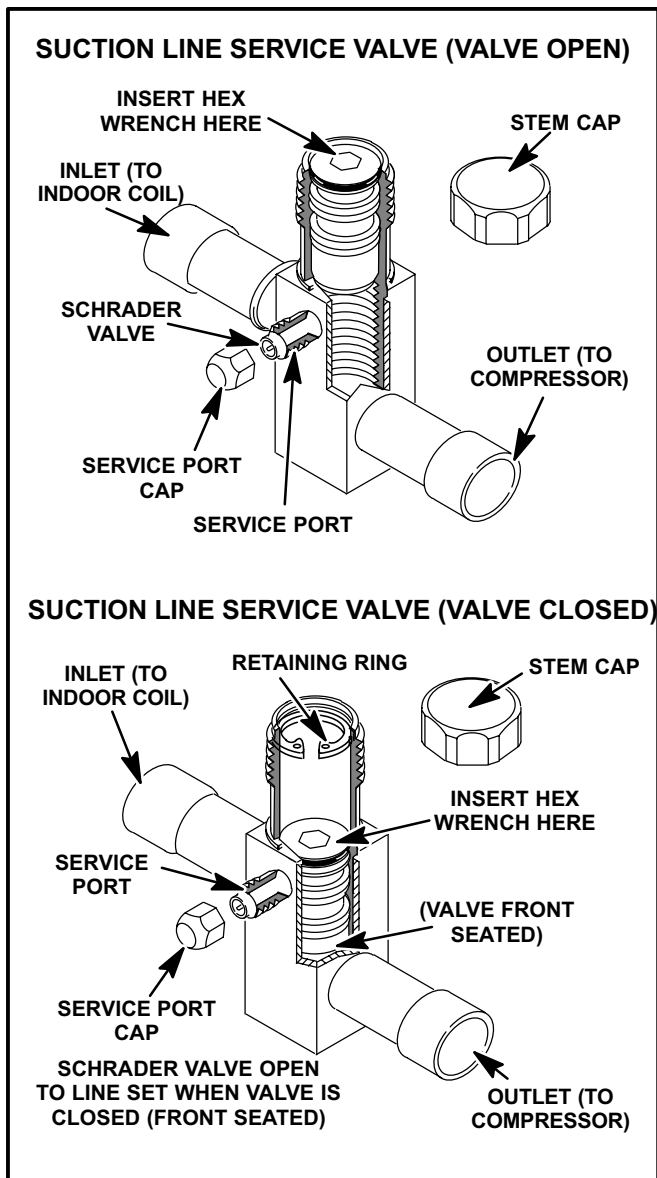

FIGURE 11

Suction Line (Ball Type) Service Valve(5 Ton Only)

A ball-type full service valve is used on 10ACB 5 ton units. These suction line service valves function the same way, differences are in construction. Valves are not rebuildable. If a valve has failed it must be replaced. A ball valve is illustrated in figure 12.

The ball valve is equipped with a service port. A schrader valve is factory installed. A service port cap is supplied to protect the schrader valve from contamination and assure a leak free seal.

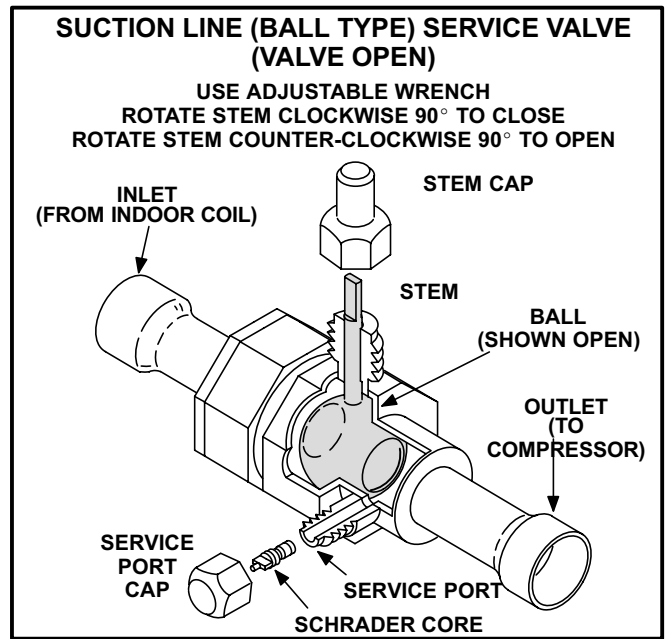

FIGURE 12

IV - CHARGING

The unit is factory-charged with the amount of R-22 refrigerant indicated on the unit rating plate. This charge is based on a matching indoor coil and outdoor coil with a 20 foot (6.1 m) line set. For varying lengths of line set, refer to table 2 for refrigerant charge adjustment. A blank space is provided on the unit rating plate to list actual field charge.

TABLE 2

LIQUID LINE SET DIAMETER	Ounce per 5 foot (ml per mm) adjust from 20 foot (6.1 m) line set*
1/4 in. (6 mm)	1 ounce per 5 feet (30 ml per 1524 mm)
5/16 in. (8mm)	2 ounce per 5 feet (60 ml per 1524 mm)
3/8 in. (10 mm)	3 ounce per 5 feet (90 ml per 1524 mm)

*If line set is greater than 20 ft. (6.1 m) add this amount. If line set is less than 20 feet (6.1 m) subtract this amount

Units are designed for line sets up to 50 ft (15.2 m). Consult Lennox Refrigerant Piping Manual for line sets over 50 ft (15.2 m).

⚠ IMPORTANT

If line length is greater than 20 feet (6.1 m) add this amount. If line length is less than 20 feet (6.1 m), subtract this amount. See table 2.

A - Pumping Down System

CAUTION

Deep vacuum operation (operating compressor at 0 psig or lower) can cause internal fusite arcing resulting in a damaged or failed compressor. This type of damage will result in denial of warranty claim.

The system may be pumped down when leak checking the line set and indoor coil or making repairs to the line set or indoor coil.

- 1- Attach gauge manifold.
- 2- Front seat (close) liquid line valve.
- 3- Start outdoor unit.
- 4- Monitor suction gauge. Stop unit when 0 psig is reached.
- 5- Front seat (close) suction line valve.

B - Leak Testing (To Be Done Before Evacuating)

- 1- Attach gauge manifold and connect a drum of dry nitrogen to center port of gauge manifold.
- 2- Open high pressure valve on gauge manifold and pressurize line set and indoor coil to 150 psig (1034 kPa).
- 3- Check lines and connections for leaks.

NOTE-If electronic leak or Halide detector is used, add a small amount of R-22 (3 to 5 psig [20kPa to 34kPa]) then pressurize with nitrogen to 150 psig.

- 4- Release nitrogen pressure from the system, correct any leaks and recheck.

CAUTION

When using dry nitrogen, a pressure reducing regulator must be used to prevent excessive pressure in gauge manifold, connecting hoses, and within the system. Regulator setting must not exceed 150 psig (1034 kPa). Failure to use a regulator can cause equipment failure resulting in injury.

C - Evacuating the System

- 1- Attach gauge manifold. Connect vacuum pump (with vacuum gauge) to center port of gauge manifold. With both manifold service valves open, start pump and evacuate indoor coil and refrigerant lines.

IMPORTANT

A temperature vacuum gauge, mercury vacuum (U-tube), or thermocouple gauge should be used. The usual Bourdon tube gauges are not accurate enough in the vacuum range.

IMPORTANT

The compressor should never be used to evacuate a refrigeration or air conditioning system.

- 2- Evacuate the system to 29 inches (737mm) vacuum. During the early stages of evacuation, it is desirable to stop the vacuum pump at least once to determine if there is a rapid loss of vacuum. A rapid loss of vacuum would indicate a leak in the system and a repeat of the leak testing section would be necessary.
- 3- After system has been evacuated to 29 inches (737mm), close gauge manifold valves to center port, stop vacuum pump and disconnect from gauge manifold. Attach an upright nitrogen drum to center port of gauge manifold and open drum valve slightly to purge line at manifold. Break vacuum in system with nitrogen pressure by opening manifold high pressure valve. Close manifold high pressure valve to center port.
- 4- Close nitrogen drum valve and disconnect from gauge manifold center port. Release nitrogen pressure from system.
- 5- Connect vacuum pump to gauge manifold center port. Evacuate system through manifold service valves until vacuum in system does not rise above .5mm of mercury absolute pressure or 500 microns within a 20-minute period after stopping vacuum pump.
- 6- After evacuation is complete, close manifold center port, and connect refrigerant drum. Pressurize system slightly with refrigerant to break vacuum.

D - Charging

If the system is completely void of refrigerant, the recommended and most accurate method of charging is to weigh the refrigerant into the unit according to the total amount shown on the unit nameplate. Also refer to the SPECIFICATIONS tables at the front of this manual.

If weighing facilities are not available or if unit is just low on charge, the following procedure applies.

1 - Expansion Valve Systems

The following procedures are intended as a general guide for use with expansion valve systems only. For best results, indoor temperature should be between 70°F and 80°F (21.1°C and 26.7°C). Outdoor temperature should be 60°F (15.6°C) or above. Slight variations in charging temperature and pressure should be expected. Large variations may indicate need for further servicing.

IMPORTANT

The following procedure requires accurate readings of ambient (outdoor) temperature, liquid temperature and liquid pressure for proper charging. Use a thermometer with accuracy of $\pm 2^\circ\text{F}$ ($\pm 1.1^\circ\text{C}$) and a pressure gauge with accuracy of ± 5 PSIG (± 34.5 kPa).

APPROACH METHOD (TXV SYSTEMS)

(Ambient Temperature of 60°F [16°C] or Above)

- 1 - Connect gauge manifold. Connect an upright R-22 drum to center port of gauge manifold.
- 2 - Record outdoor air (ambient) temperature.
- 3 - Operate indoor and outdoor units in cooling mode. Allow outdoor unit to run until system pressures stabilize.
- 4 - Make sure thermometer well is filled with mineral oil before checking liquid line temperature.
- 5 - Place thermometer in well and read liquid line temperature. Liquid line temperature should be warmer than the outdoor air temperature. Tables 3 and 4 show how many degrees warmer the liquid line temperature should be.

Add refrigerant to lower the liquid line temperature.

Recover refrigerant to raise the liquid line temperature.

Add refrigerant slowly as the unit approaches the correct temperature. This will allow refrigerant to stabilize allowing the correct temperature to be read.

TABLE 3
-1 through -8 Models

MODEL NO.	APPROACH TEMPERATURE LIQUID LINE - OUTDOOR AMBIENT °F (°C)
10ACB18	4 (2.2)
10ACB24	5 (2.8)
10ACB30	10 (5.6)
10ACB36	12 (6.7)
10ACB42	12 (6.7)
10ACB48	13 (7.2)
10ACB60	13 (7.2)

Note - For best results, the same electronic thermometer should be used to check both outdoor ambient and liquid temperatures.

TABLE 4
-9 and Higher Models

MODEL NO.	APPROACH TEMPERATURE LIQUID LINE - OUTDOOR AMBIENT °F (°C)
10ACB12	7 (3.9)
10ACB18	5 (2.8)
10ACB24	9 (5)
10ACB30	10 (5.6)
10ACB36	12 (6.7)
10ACB42	14 (8)
10ACB48	13 (7.2)
10ACB60	12 (6.7)

Note - For best results, the same electronic thermometer should be used to check both outdoor ambient and liquid temperatures.

6 - When unit is properly charged, liquid line pressures should approximate those in table 5 or table 6.

TABLE 5
-1 through -8 Models

OUTDOOR COIL ENTERING AIR TEMPERATURE	NORMAL OPERATING PRESSURES*													
	10ACB18		10ACB24		10ACB30		10ACB36		10ACB42		10ACB48		10ACB60	
	LIQ. ± 10 PSIG	SUC. ± 10 PSIG	LIQ. ± 10 PSIG	SUC. ± 10 PSIG	LIQ. ± 10 PSIG	SUC. ± 10 PSIG	LIQ. ± 10 PSIG	SUC. ± 10 PSIG	LIQ. ± 10 PSIG	SUC. ± 10 PSIG	LIQ. ± 10 PSIG	SUC. ± 10 PSIG	LIQ. ± 10 PSIG	SUC. ± 10 PSIG
65°F (18.3°C) (RFCIV)	155	65	160	65	168	63	176	62	174	64	181	65	---	---
75°F (23.9°C) (RFCIV)	181	70	188	70	197	68	203	66	205	69	208	70	---	---
85°F (29.4°C) (RFCIV)	208	75	216	74	227	73	233	70	236	73	239	75	---	---
95°F (35.0°C) (RFCIV)	238	80	247	78	258	77	266	74	271	77	271	79	---	---
105°F (40.6°C) (RFCIV)	270	84	280	82	292	80	299	77	305	80	306	82	---	---
65°F (18.3°C) (TXV)	159	73	164	71	173	71	179	68	180	71	187	73	174	70
75°F (23.92°C) (TXV)	183	75	189	73	199	73	205	70	208	73	212	75	203	72
85°F (31.2°C) (TXV)	209	77	217	75	228	75	235	72	238	75	241	77	235	74
95°F (31.2°C) (TXV)	238	80	247	78	258	77	266	74	271	77	271	79	269	76
105°F (31.2°C) (TXV)	269	82	279	80	292	79	299	77	305	79	305	80	306	78

*These are typical pressures only. Indoor evaporator match up, indoor air quality and evaporator load will cause the pressures to vary.

TABLE 6
-9 and Higher Models

NORMAL OPERATING PRESSURES IN PSIG (LIQUID AND SUCTION +/- 10 PSIG)*																			
MODE	OUT. COIL ENTERING AIR TEMP. °F (°C)	10ACB12		10ACB18		10ACB24		10ACB30		10ACB36		10ACB42		10ACB48		10ACB60		10ACB62	
		LIQ.	SUC.	LIQ.	SUC.	LIQ.	SUC.	LIQ.	SUC.	LIQ.	SUC.	LIQ.	SUC.	LIQ.	SUC.	LIQ.	SUC.	LIQ.	SUC.
RFCIV	65 (18.3)	145	71	155	65	160	65	168	63	176	62	162	68	157	69	153	66	159	64
	75 (23.9)	167	77	181	70	188	70	197	68	203	66	185	72	182	72	180	71	188	68
	85 (29.4)	192	81	208	75	216	74	227	73	233	70	210	73	204	73	210	74	219	72
	95 (35.0)	221	84	238	80	247	78	258	77	266	74	252	76	244	76	245	77	253	75
	105 (40.6)	253	87	270	84	280	82	292	80	299	77	287	79	278	79	279	79	287	76
TXV	65 (18.3)	140	79	159	73	164	71	173	71	179	68	157	71	158	70	142	73	151	69
	75 (23.9)	161	80	183	75	189	73	199	73	205	70	187	73	182	72	168	75	179	71
	85 (29.4)	189	81	209	77	217	75	228	75	235	72	217	74	205	73	202	76	211	73
	95 (35.0)	220	83	238	80	247	78	258	77	266	74	255	76	246	76	245	77	249	74
	105 (40.6)	254	84	269	82	279	80	292	79	299	77	289	77	280	79	280	78	286	75

*These are typical pressures only. Indoor evaporator match up, indoor air quality and evaporator load will cause the pressures to vary.

! IMPORTANT

Use table 5 or 6 as a general guide for performing maintenance checks. Tables 5 and 6 are not a procedure for charging the system. Minor variations in these pressures may be expected due to differences in installations. Significant deviations could mean that the system is not properly charged or that a problem exists with some component in the system. Used prudently, tables 5 and 6 could serve as a useful service guide.

2 - RFCIV Systems

The following procedures are intended as a general guide for use with RFCIV systems only. For best results, indoor temperature should be between 70°F and 80°F (21.1°C and 26.7°C). Outdoor temperature should be 60°F (15.6°C) or above. Slight variations in charging temperature and pressure should be expected. Large variations may indicate a need for further servicing.

- 1 - Operate indoor and outdoor units. Allow outdoor unit to run until system pressures stabilize.
- 2 - Make sure thermometer well is filled with mineral oil before checking liquid line temperature.
- 3 - Read liquid line pressure and convert to condensing temperature using temperature/ pressure conversion chart.
Condensing temperature (read from gauges) should be warmer than liquid line temperature.
- 4 - Place thermometer in well and read liquid line temperature. Tables 7 and 8 shows how much warmer the condensing temperature should be.
- 5 - Subtract liquid line temperature from condensing temperature to determine subcooling. Compare with table 7 or 8.
Add refrigerant to lower liquid line temperature.
Recover refrigerant to raise liquid line temp.
- 6 - When unit is properly charged liquid line pressures should approximate table 5 or 6.

TABLE 7
-1 through -8 Models

Outdoor Temperature °F (°C)	Liquid Subcooling (± 1°F or 0.5 °C)					
	10ACB18	10ACB24	10ACB30	10ACB36	10ACB42	10ACB48
60 (16)	17 (9.5)	18 (10)	18 (10)	14 (8)	16 (8.9)	15 (8.3)
65 (18)	16 (8.9)	16 (8.9)	17 (9.5)	13 (7.8)	15 (8.3)	14 (8)
70 (21)	15 (8.3)	14 (8)	16 (8.9)	12 (6.7)	14 (8)	13 (7.8)
75 (24)	14 (8)	12 (6.7)	15 (8.3)	10 (5.6)	13 (7.8)	11 (6.1)
80 (27)	13 (7.8)	11 (6.1)	14 (8)	9 (5)	12 (6.7)	10 (5.6)
85 (29)	12 (6.7)	10 (5.6)	13 (7.8)	8 (4.4)	11 (6.1)	8 (4.4)
90 (32)	11 (6.1)	9 (5)	12 (6.7)	7 (3.9)	10 (5.6)	7 (3.9)
95 (35)	9 (5)	8 (4.4)	11 (6.1)	6 (3.3)	9 (5)	7 (3.9)
100 (38)	8 (4.4)	7 (3.9)	10 (5.6)	5 (2.8)	8 (4.4)	6 (3.3)
105 (41)	7 (3.9)	6 (3.3)	9 (5)	4 (2.2)	6 (3.3)	4 (2.2)
110 (43)	6 (3.3)	6 (3.3)	7 (3.9)	3 (1.7)	5 (2.8)	3 (1.7)
115 (46)	5 (2.8)	5 (2.8)	5 (2.8)	2 (1.1)	3 (1.7)	2 (1.1)

TABLE 8
-9 and Higher Models

OUTDOOR TEMP. °F (°C)	LIQUID SUBCOOLING [± 1°F (.6 °C)]							
	012	018	024	030	036	042	048	060
60 (16)	14 (7.8)	17 (9.5)	18 (10)	18 (10)	14 (8)	14 (8)	12 (6.7)	14 (8)
65 (18)	13 (7.2)	16 (8.9)	16 (8.9)	17 (9.5)	13 (7.8)	13 (7.8)	11 (6.1)	14 (8)
70 (21)	12 (6.7)	15 (8.3)	14 (7.8)	16 (8.9)	12 (6.7)	13 (7.8)	10 (5.6)	13 (7.8)
75 (24)	10 (5.6)	14 (7.8)	12 (6.7)	15 (8.3)	10 (5.6)	12 (6.7)	9 (5)	13 (7.8)
80 (27)	9 (5)	13 (7.2)	11 (6.1)	14 (8)	9 (5)	11 (6.1)	9 (5)	12 (6.7)
85 (29)	8 (4.5)	12 (6.7)	10 (5.6)	13 (7.8)	8 (4.4)	10 (5.6)	9 (5)	12 (6.7)
90 (32)	7 (3.9)	11 (6.1)	9 (5)	12 (6.7)	7 (3.9)	10 (5.6)	8 (4.5)	12 (6.7)
95 (35)	6 (3.3)	9 (5)	8 (4.5)	11 (6.1)	6 (3.3)	9 (5)	8 (4.5)	12 (6.7)
100 (38)	4 (2.2)	8 (4.5)	7 (3.9)	10 (5.6)	5 (2.8)	9 (5)	8 (4.5)	11 (6.1)
105 (41)	2 (1.1)	7 (3.9)	6 (3.3)	9 (5)	4 (2.2)	9 (5)	7 (3.9)	10 (5.6)
110 (43)	2 (1.1)	6 (3.3)	6 (3.3)	7 (3.9)	3 (1.7)	8 (4.5)	7 (3.9)	9 (5)
115 (45)	1 (0.6)	5 (2.8)	5 (2.8)	5 (2.8)	2 (1.1)	7 (3.9)	6 (3.3)	8 (4.5)

Note - For best results, the same electronic thermometer should be used to check both outdoor ambient and liquid temperatures.

E - Oil Charge

Refer to compressor nameplate.

V - MAINTENANCE

At the beginning of each heating or cooling season, the system should be cleaned as follows:

A - Outdoor Unit

- 1 - Clean and inspect condenser coil. (Coil may be flushed with a water hose).
- 2 - Visually inspect all connecting lines, joints and coils for evidence of oil leaks.

B - Indoor Coil

- 1 - Clean coil if necessary.
- 2 - Check connecting lines and coil for evidence of oil leaks.
- 3 - Check condensate line and clean if necessary.

C - Indoor Unit

- 1 - Clean or change filters.
- 2 - Bearings are pre-lubricated and need no further oiling.
- 3 - Check all wiring for loose connections.
- 4 - Check for correct voltage at unit.
- 5 - Check amp-draw on blower motor.

Unit nameplate _____ Actual _____.

VI - WIRING DIAGRAMS AND SEQUENCE OF OPERATION

10ACB OPERATING SEQUENCE RECIPROCATING COMPRESSOR

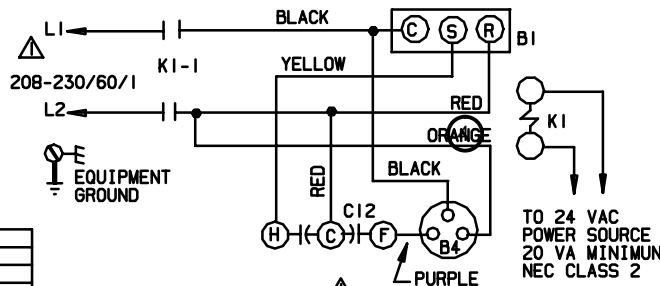
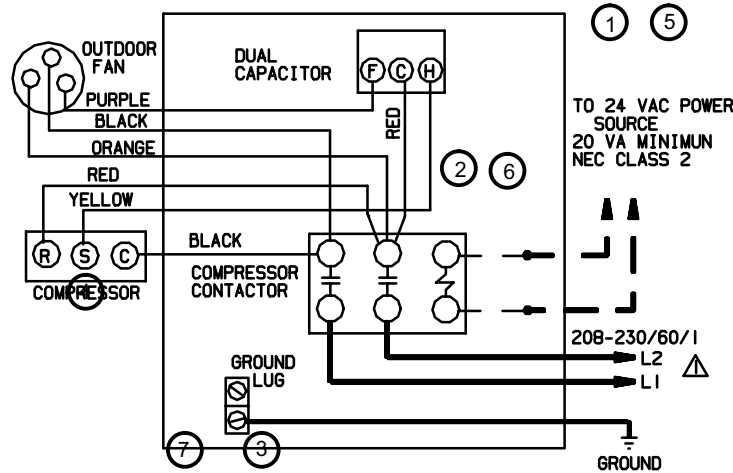

KEY	DESCRIPTION
B1	COMPRESSOR
B4	MOTOR-OUTDOOR FAN
C12	CAPACITOR-DUAL
K1, -1	CONTACTOR-COMPRESSOR

NOTE-
FOR USE WITH COPPER CONDUCTORS
ONLY. REFER TO UNIT RATING
PLATE FOR MINIMUM CIRCUIT
AMPACITY AND MAXIMUM OVER-
CURRENT PROTECTION SIZE

— LINE VOLTAGE FIELD INSTALLED
- - - CLASS II VOLTAGE FIELD INSTALLED

WARNING-
ELECTRIC SHOCK HAZARD, CAN CAUSE INJURY OR
DEATH. UNIT MUST BE GROUND IN ACCORDANCE
WITH NATIONAL AND LOCAL CODES.

LENNOX Industries Inc. WIRING DIAGRAM 5/98	
COOLING UNITS-CONDENSING UNITS	
10ACB12-9P, 10P	10ACB30-9P, 10P
10ACB18-9P, 10P	10ACB36-9P, 10P, 11P
10ACB24-9P, 10P	
COOLING UNITS-B	
Supersede Form No. 532, 680W	New Form No. 532, 857W
©1998 Lennox Industries Inc.	Litho U.S.A.

A-10ACB 1-1/2 - 3 TON OPERATING SEQUENCE

This is the sequence of operation for 10ACB 1-1/2 through 3 ton units. The sequence is outlined by numbered steps which correspond to circled numbers on the adjacent diagram.

NOTE- The thermostat used may be electromechanical or electronic.

NOTE- Transformer in indoor unit supplies power (24 VAC) to the thermostat and outdoor unit controls.

COOLING:

- 1 - Cooling demand initiates at Y1 in the thermostat.
- 2 - 24VAC energizes compressor contactor K1.
- 3 - K1-1 N.O. closes, energizing compressor (B1) and outdoor fan motor (B4).
- 4 - Compressor (B1) and outdoor fan motor (B4) begin immediate operation.

END OF COOLING DEMAND:

- 5 - Cooling demand is satisfied. Terminal Y1 is de-energized.
- 6 - Compressor contactor K1 is de-energized.
- 7 - K1-1 opens and compressor (B1) and outdoor fan motor (B4) are de-energized and stop immediately.

10ACB OPERATING SEQUENCE RECIPROCATING COMPRESSOR

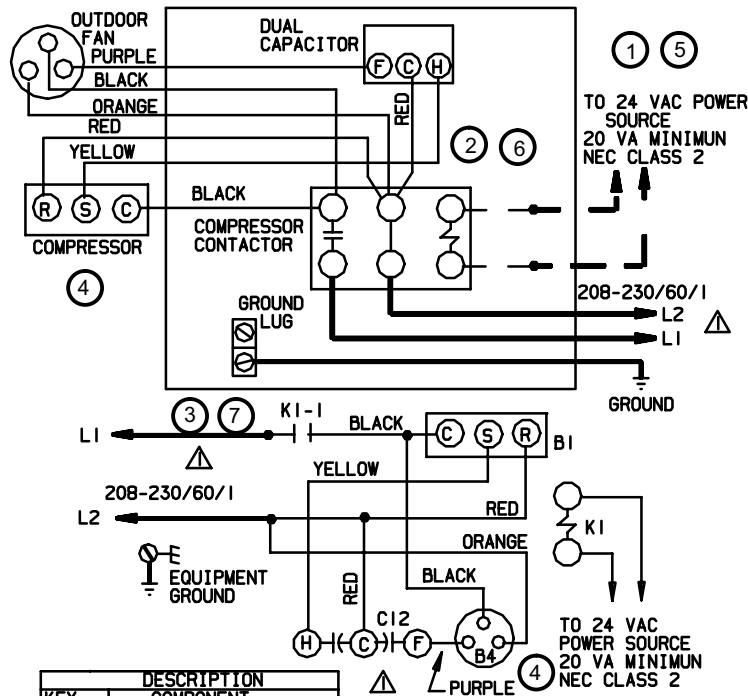

DESCRIPTION	
KEY	COMPONENT
B1	COMPRESSOR
B4	MOTOR-OUTDOOR FAN
C12	CAPACITOR-DUAL
K1, -1	CONTACTOR-COMPRESSOR

NOTE-
FOR USE WITH COPPER CONDUCTORS
ONLY. REFER TO UNIT RATING
PLATE FOR MINIMUM CIRCUIT
AMPACITY AND MAXIMUM OVER-
CURRENT PROTECTION SIZE.

WARNING-
ELECTRIC SHOCK HAZARD, CAN CAUSE INJURY OR
DEATH. UNIT MUST BE GROUNDED IN ACCORDANCE
WITH NATIONAL AND LOCAL CODES.

— LINE VOLTAGE FIELD INSTALLED
- - - CLASS 11 VOLTAGE FIELD INSTALLED

LENNOX® COOLING UNITS- CONDENSING UNITS	
10ACB12-10P, 11P	10ACB30-11P, 12P
10ACB18-11P	10ACB36-12P, 13P
10ACB24-11P	
0700	Superseded Form No. 533, 472W
	New Form No. 533, 486W

©2000 Lennox Industries Inc.

Litho U.S.A.

A-10ACB 1-1/2 - 3 TON OPERATING SEQUENCE

This is the sequence of operation for 10ACB 1-1/2 through 3 ton units. The sequence is outlined by numbered steps which correspond to circled numbers on the adjacent diagram.

NOTE- The thermostat used may be electromechanical or electronic.

NOTE- Transformer in indoor unit supplies power (24 VAC) to the thermostat and outdoor unit controls.

COOLING:

- 1 - Cooling demand initiates at Y1 in the thermostat.
- 2 - 24VAC energizes compressor contactor K1.
- 3 - K1-1 N.O. closes, energizing compressor (B1) and outdoor fan motor (B4).
- 4 - Compressor (B1) and outdoor fan motor (B4) begin immediate operation.

END OF COOLING DEMAND:

- 5 - Cooling demand is satisfied. Terminal Y1 is de-energized.
- 6 - Compressor contactor K1 is de-energized.
- 7 - K1-1 opens and compressor (B1) and outdoor fan motor (B4) are de-energized and stop immediately.

10ACB OPERATING SEQUENCE RECIPROCATING COMPRESSOR

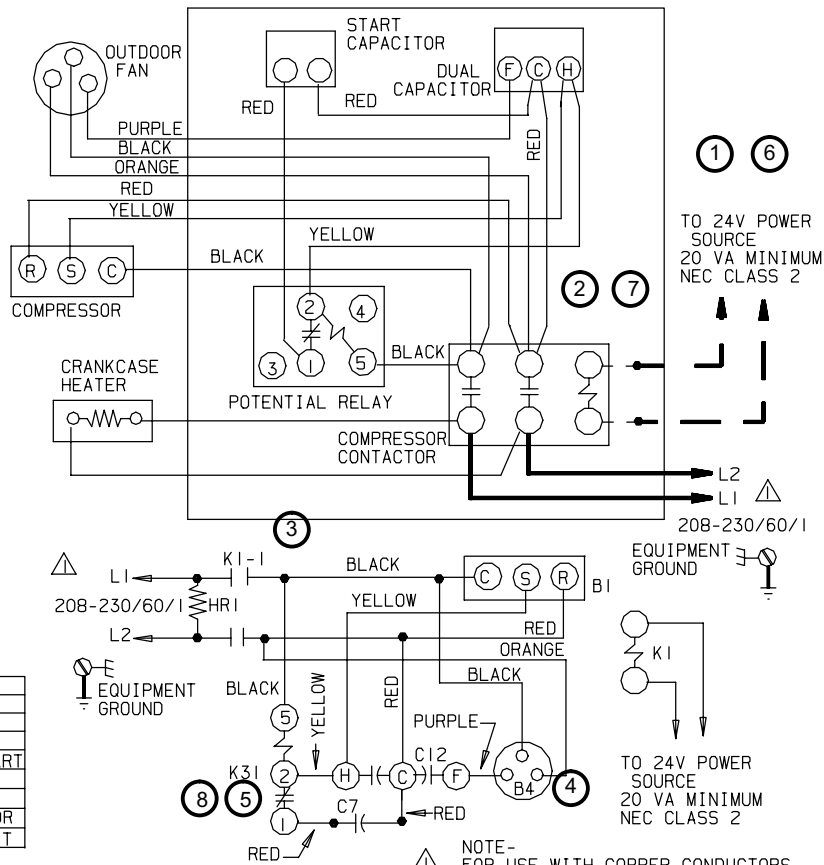

KEY	DESCRIPTION
B1	COMPRESSOR
B4	MOTOR-OUTDOOR FAN
C7	CAPACITOR-DUAL START
C12	CAPACITOR-DUAL
HR1	HEATER-COMPRESSOR
K1, -1	CONTACTOR-COMPRESSOR
K31	RELAY-HARD START KIT

LENNOX Industries Inc. WIRING DIAGRAM 7/94	
COOLING UNITS-CONDENSING UNITS	
10ACB42-1P, -2P	
10ACB48-1P, -2P	
10ACB60-1P, -2P	
COOLING UNITS-B	
Supersedes Form No.	New Form No.
	531, 169W
© 1994 Lennox Industries Inc. Litho U.S.A.	

A-10ACB 3-1/2 - 5 TON OPERATING SEQUENCE

This is the sequence of operation for 10ACB 3-1/2 through 5 ton units. The sequence is outlined by numbered steps which correspond to circled numbers on the adjacent diagram.

NOTE- The thermostat used may be electromechanical or electronic.

NOTE- Transformer in indoor unit supplies power (24 VAC) to the thermostat and outdoor unit controls.

COOLING:

- 1 - Cooling demand initiates at Y1 in the thermostat.
- 2 - 24VAC from indoor unit energizes compressor contactor K1.
- 3 - K1-1 N.O. closes, energizing terminal "C" of compressor (B1) and outdoor fan motor (B4).
- 4 - Outdoor fan motor (B4) begins immediate operation.
- 5 - Compressor (B1) begins start-up. Hard start contactor K31 remains closed during start-up and start capacitor C7 remains in the circuit. As the compressor gains speed, K31 is energized. When K31 is energized, the contacts open and start capacitor C7 is taken out of the circuit.

END OF COOLING DEMAND:

- 6 - Cooling demand is satisfied. Terminal Y1 is de-energized.
- 7 - Compressor contactor K1 is de-energized.
- 8 - K1-1 opens and compressor (B1) and outdoor fan motor (B4) are de-energized and stop immediately.

10ACB OPERATING SEQUENCE SCROLL COMPRESSOR

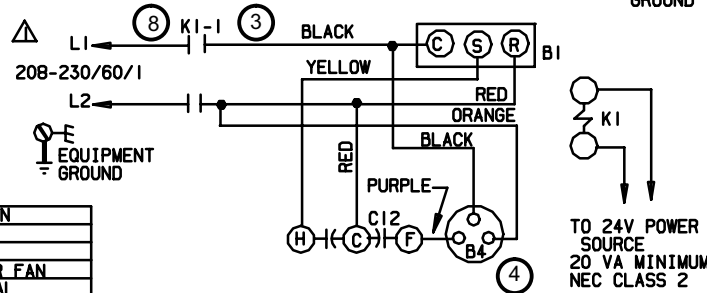
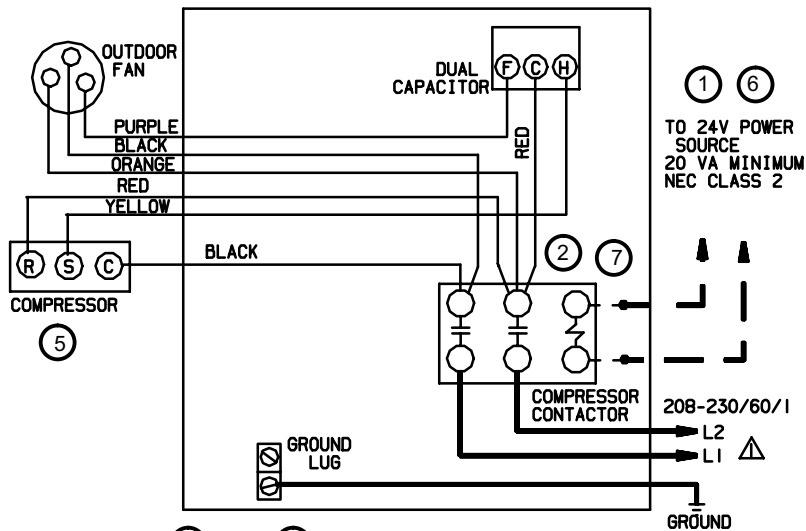

KEY	DESCRIPTION
B1	COMPRESSOR
B4	MOTOR-OUTDOOR FAN
C12	CAPACITOR-DUAL
K1, -1	CONTACTOR-COMPRESSOR

△ NOTE-
FOR USE WITH COPPER CONDUCTORS
ONLY. REFER TO UNIT RATING
PLATE FOR MINIMUM CIRCUIT
AMPACITY AND MAXIMUM OVER-
CURRENT PROTECTION SIZE

WARNING-
ELECTRIC SHOCK HAZARD, CAN CAUSE INJURY OR
DEATH. UNIT MUST BE GROUND IN ACCORDANCE
WITH NATIONAL AND LOCAL CODES.

— LINE VOLTAGE FIELD INSTALLED
— CLASS 11 VOLTAGE FIELD INSTALLED

LENNOX Industries Inc. WIRING DIAGRAM 2/98	
COOLING UNITS-CONDENSING UNITS	
10ACB42-11P 10ACB48-10P 10ACB60-10P	
COOLING UNITS-B	
Supersedes Form No.	New Form No. 532,716W
©1998 Lennox Industries Inc. Litho U.S.A.	

A-10ACB 3-1/2 - 5 TON OPERATING SEQUENCE

This is the sequence of operation for 10ACB 3-1/2 through 5 ton units. The sequence is outlined by numbered steps which correspond to circled numbers on the adjacent diagram.

NOTE- The thermostat used may be electromechanical or electronic.

NOTE- Transformer in indoor unit supplies power (24 VAC) to the thermostat and outdoor unit controls.

COOLING:

- 1 - Cooling demand initiates at Y1 in the thermostat.
- 2 - 24VAC from indoor unit energizes compressor contactor K1.
- 3 - K1-1 N.O. closes, energizing terminal "C" of compressor (B1) and outdoor fan motor (B4).
- 4 - Outdoor fan motor (B4) begins immediate operation.
- 5 - Compressor (B1) begins start-up.

END OF COOLING DEMAND:

- 6 - Cooling demand is satisfied. Terminal Y1 is de-energized.
- 7 - Compressor contactor K1 is de-energized.
- 8 - K1-1 opens and compressor (B1) and outdoor fan motor (B4) are de-energized and stop immediately.

10ACB OPERATING SEQUENCE SCROLL COMPRESSOR

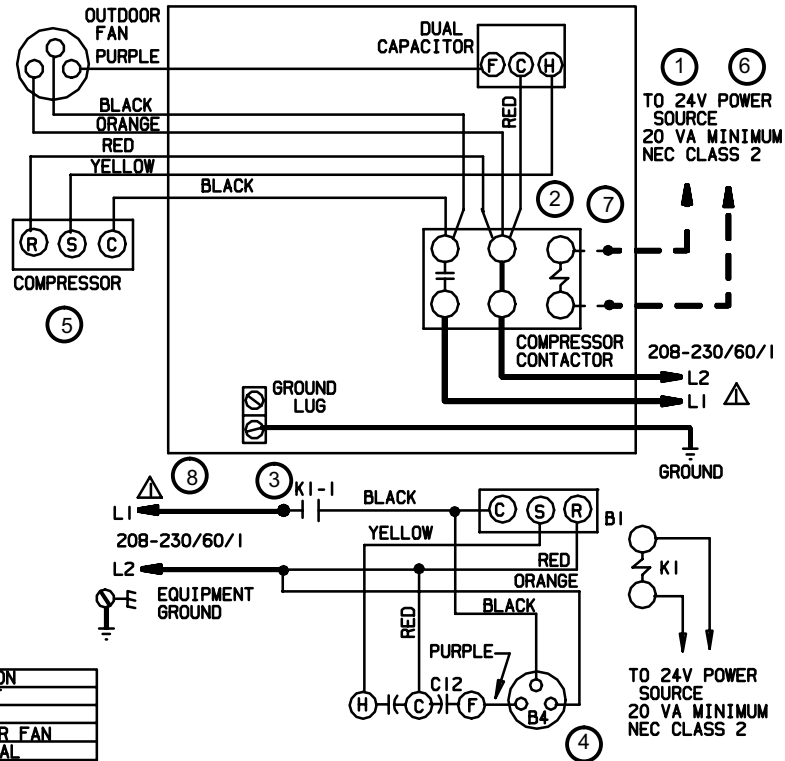

KEY	DESCRIPTION
	COMPONENT
B1	COMPRESSOR
B4	MOTOR-OUTDOOR FAN
C12	CAPACITOR-DUAL
K1, -1	CONTACTOR-COMPRESSOR

LENNOX® COOLING UNITS- CONDENSING UNITS	
10ACB42-12P 10ACB48-11P 10ACB60-11P	
0500	Supersedes Form No.
	New Form No.
	533, 473W

©2000 Lennox Industries Inc.

Littleton, U.S.A.

NOTE-
FOR USE WITH COPPER CONDUCTORS
ONLY. REFER TO UNIT RATING
PLATE FOR MINIMUM CIRCUIT
AMPACITY AND MAXIMUM OVER-
CURRENT PROTECTION SIZE.

WARNING-
ELECTRIC SHOCK HAZARD, CAN CAUSE INJURY OR
DEATH. UNIT MUST BE GROUNDED IN ACCORDANCE
WITH NATIONAL AND LOCAL CODES.

— LINE VOLTAGE FIELD INSTALLED
- - - CLASS II VOLTAGE FIELD INSTALLED

A-10ACB 3-1/2 - 5 TON OPERATING SEQUENCE

This is the sequence of operation for 10ACB 3-1/2 through 5 ton units. The sequence is outlined by numbered steps which correspond to circled numbers on the adjacent diagram.

NOTE- The thermostat used may be electromechanical or electronic.

NOTE- Transformer in indoor unit supplies power (24 VAC) to the thermostat and outdoor unit controls.

COOLING:

- 1 - Cooling demand initiates at Y1 in the thermostat.
- 2 - 24VAC from indoor unit energizes compressor contactor K1.
- 3 - K1-1 N.O. closes, energizing terminal "C" of compressor (B1) and outdoor fan motor (B4).
- 4 - Outdoor fan motor (B4) begins immediate operation.
- 5 - Compressor (B1) begins start-up.

END OF COOLING DEMAND:

- 6 - Cooling demand is satisfied. Terminal Y1 is de-energized.
- 7 - Compressor contactor K1 is de-energized.
- 8 - K1-1 opens and compressor (B1) and outdoor fan motor (B4) are de-energized and stop immediately.