

**CB26UH and CBX26UH Series**

**Table of Contents**



Model Number Information ..... 2

Specifications / Electrical Data ..... 3

Blower Data ..... 5

I Application ..... 9

II Unit Components ..... 9

III Optional Electric Heat ..... 10

IV Configuration Modification ..... 16

V Start Up ..... 18

VI Typical Operating Characteristics ..... 19

VII Maintenance ..... 19

VIII Wiring Diagrams ..... 20

The CB26UH, and CBX26UH are high efficiency blower coils. Several models are available in sizes ranging from 1-1/2 through 5 tons (5.3 through 17.6 kW). The CBX26UH is designed for HFC-410A refrigerant and the CB26UH is designed for HCFC-22 refrigerant. The units are up flow / horizontal that can be field converted to down flow applications. The units come with a factory installed check and expansion valve for cooling or heat pump applications.

CB26UH and CBX26UH series units are designed to be matched with the 13SEER air conditioner and heat pump line, but can be matched with other air conditioners or heat pumps as noted in the rating information. See Engineering Handbook.

Electric heat, in several kW sizes, can be field installed in the CB26UH and CBX26UH cabinets.

Information contained in this manual is intended for use by experienced HVAC service technicians only. All specifications are subject to change. Procedures outlined in this manual are presented as a recommendation only and do not supersede or replace local or state codes.

**⚠ WARNING**

Improper installation, adjustment, alteration, service or maintenance can cause personal injury, loss of life, or damage to property.

Installation and service must be performed by a licensed professional installer (or equivalent) or a service agency.

**⚠ CAUTION**

Physical contact with metal edges and corners while applying excessive force or rapid motion can result in personal injury. Be aware of, and use caution when working near these areas during installation or while servicing this equipment.

**⚠ IMPORTANT**

The Clean Air Act of 1990 bans the intentional venting of refrigerant (CFCs, HCFCs and HFCs) as of July 1, 1992. Approved methods of recovery, recycling or reclaiming must be followed. Fines and/or incarceration may be levied for noncompliance.

**MODEL NUMBER IDENTIFICATION**

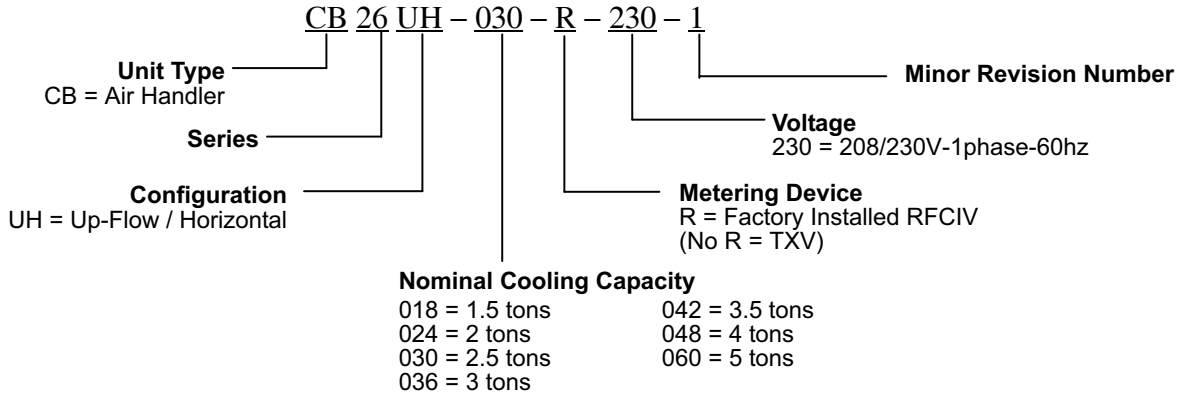

**MODEL NUMBER IDENTIFICATION**

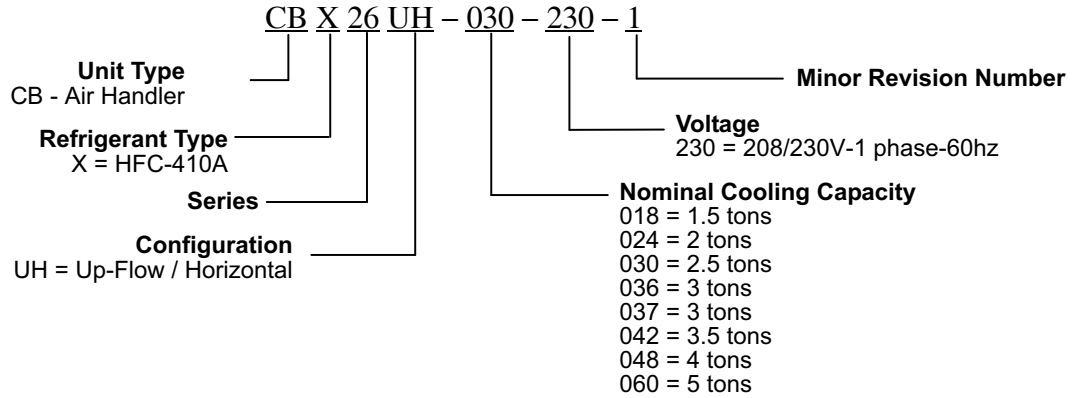

**SPECIFICATIONS — CB(X)26UH-0XX-(R)-230-01 Build**

General Data		Model Number	CBX26UH-018	CBX26UH-024	CBX26UH-030	CBX26UH-036
		Nominal tonnage	1.5	2	2.5	3
<b>Connections</b>	Suction/Vapor line (o.d.) - in. (mm) sweat		3/4 (19)	3/4 (19)	7/8 (22.2)	7/8 (22.2)
	Liquid line (o.d.) - in. (mm) sweat		3/8 (9.5)	3/8 (9.5)	3/8 (9.5)	3/8 (9.5)
	Condensate - in. (mm) fpt		(2) 3/4 (19)	(2) 3/4 (19)	(2) 3/4 (19)	(2) 3/4 (19)
<b>Indoor Coil</b>	Net face area - ft. <sup>2</sup> (m <sup>2</sup> )		4 (0.37)	4 (0.37)	4.88 (0.45)	4.88 (0.45)
	Tube outside diameter - in. (mm)		3/8 (9.5)	3/8 (9.5)	3/8 (9.5)	3/8 (9.5)
	Number of rows		3	3	3	3
	Fins per inch (fins per m)		15 (591)	14 (551)	14 (551)	14 (551)
<b>Blower</b>	Wheel nominal diameter x width - in. (mm)		10 x 6 (254 x 152)	10 x 6 (254 x 152)	11 x 8 (279 x 203)	11 x 8 (279 x 203)
	Blower motor output - hp (W)		1/4 (187)	1/4 (187)	1/4 (187)	1/3 (249)
<sup>1</sup> <b>Filters</b>	Size of filter - in. (mm)		15 x 20 x 1 (406 x 508 x 25)	15 x 20 x 1 (406 x 508 x 25)	18 x 20 x 1 (457 x 508 x 25)	18 x 20 x 1 (457 x 508 x 25)

**ELECTRICAL DATA**

	Voltage - 1 phase (60 hz)	208/240V	208/240V	208/240V	208/240V
	<sup>2</sup> Maximum overcurrent protection (unit only)	15	15	15	15
	<sup>3</sup> Minimum circuit ampacity (unit only)	1.5	1.5	1.6	2.0
<b>Shipping Data -1 package - lbs. (kg)</b>		129 (58)	131 (59)	148 (67)	148 (67)

**SPECIFICATIONS — CB(X)26UH-0XX-(R)-230-01 Build**

General Data		Model Number	CBX26UH-037	CBX26UH-042	CBX26UH-048	CBX26UH-060
		Nominal tonnage	3	3.5	4	5
<b>Connections</b>	Suction/Vapor line (o.d.) - in. (mm) sweat		7/8 (22.2)	7/8 (22.2)	7/8 (22.2)	7/8 (22.2)
	Liquid line (o.d.) - in. (mm) sweat		3/8 (9.5)	3/8 (9.5)	3/8 (9.5)	3/8 (9.5)
	Condensate - in. (mm) fpt		(2) 3/4 (19)	(2) 3/4 (19)	(2) 3/4 (19)	(2) 3/4 (19)
<b>Indoor Coil</b>	Net face area - ft. <sup>2</sup> (m <sup>2</sup> )		5.84 (0.54)	5.84 (0.54)	7.58 (0.70)	8.76 (0.81)
	Tube outside diameter - in. (mm)		3/8 (9.5)	3/8 (9.5)	3/8 (9.5)	3/8 (9.5)
	Number of rows		3	3	3	3
	Fins per inch (fins per m)		14 (551)	14 (551)	14 (551)	14 (551)
<b>Blower</b>	Wheel nominal diameter x width - in. (mm)		11 x 8 (279 x 203)	11 x 8 (279 x 203)	11 x 8 (279 x 203)	11-1/2 x 9 (292 x 229)
	Blower motor output - hp (W)		1/3 (249)	1/3 (249)	1/2 (373)	1/2 (373)
<sup>1</sup> <b>Filters</b>	Size of filter - in. (mm)		18 x 25 x 1 (457 x 635 x 25)	18 x 25 x 1 (457 x 635 x 25)	18 x 25 x 1 (457 x 635 x 25)	18 x 25 x 1 (457 x 635 x 25)

**ELECTRICAL DATA**

	Voltage - 1 phase (60 hz)	208/240V	208/240V	208/240V	208/240V
	<sup>2</sup> Maximum overcurrent protection (unit only)	15	15	15	15
	<sup>3</sup> Minimum circuit ampacity (unit only)	1.8	2.0	2.6	4.1
<b>Shipping Data -1 package - lbs. (kg)</b>		172 (78)	172 (78)	177 (80)	190 (86)

<sup>1</sup> Filter is not furnished and must be field supplied.

<sup>2</sup> HACR type circuit breaker or fuse.

<sup>3</sup> Refer to National or Canadian Electrical Code manual to determine wire, fuse and disconnect size requirements. Use wires suitable for at least 167°F (75°C).

**SPECIFICATIONS — CB(X)26UH-0XX-(R)-230-02 Build<sup>4</sup>**

<b>General Data</b>		<b>Model Number</b>	<b>CBX26UH-042</b>	<b>CBX26UH-048</b>	<b>CBX26UH-060</b>
		Nominal tonnage	3.5	4	5
<b>Connections</b>	Suction/Vapor line (o.d.) - in. (mm) sweat		7/8 (22.2)	7/8 (22.2)	7/8 (22.2)
	Liquid line (o.d.) - in. (mm) sweat		3/8 (9.5)	3/8 (9.5)	3/8 (9.5)
	Condensate - in. (mm) fpt		(2) 3/4 (19)	(2) 3/4 (19)	(2) 3/4 (19)
<b>Indoor Coil</b>	Net face area - ft. <sup>2</sup> (m <sup>2</sup> )		5.84 (0.54)	7.58 (0.70)	8.76 (0.81)
	Tube outside diameter - in. (mm)		3/8 (9.5)	3/8 (9.5)	3/8 (9.5)
	Number of rows		3	3	3
	Fins per inch (fins per m)		14 (551)	14 (551)	14 (551)
<b>Blower</b>	Wheel nominal diameter x width - in. (mm)		11 x 8 (279 x 203)	11-1/2 x 9 (279 x 203)	12 x 9 (292 x 229)
	Blower motor output - hp (W)		1/2 (373)	1/2 (373)	1/2 (373)
<sup>1</sup> <b>Filters</b>	Size of filter - in. (mm)		18 x 25 x 1 (457 x 635 x 25)	18 x 25 x 1 (457 x 635 x 25)	18 x 25 x 1 (457 x 635 x 25)
<b>Shipping Data -1 package - lbs. (kg)</b>			172 (78)	177 (80)	190 (86)
<b>ELECTRICAL DATA</b>					
Voltage - 1 phase (60 hz)			208/240V	208/240V	208/240V
<sup>2</sup> Maximum overcurrent protection (unit only)			15	15	15
<sup>3</sup> Minimum circuit ampacity (unit only)			2.0	2.6	4.1

<sup>1</sup> Filter is not furnished and must be field supplied.

<sup>2</sup> HACR type circuit breaker or fuse.

<sup>3</sup> Refer to National or Canadian Electrical Code manual to determine wire, fuse and disconnect size requirements. Use wires suitable for at least 167°F (75°C).

<sup>4</sup> Only the 3.5, 4 and 5 ton units had specifications changed for -02 build. Use previous specification section for all other sizes.

## BLOWER DATA

The following tables pertain to the -01 build — CB(X)26UH-0XX-230-01:

### CB(X)26UH-018-230-01 BLOWER PERFORMANCE

External Static Pressure		Air Volume at Specific Blower Taps			
		High		Low	
in. w.g.	Pa	cfm	L/s	cfm	L/s
.10	25	1020	460	755	340
.20	50	960	435	715	325
.30	75	885	400	675	305
.40	100	800	365	625	285
.50	125	690	315	570	260
.60	150	525	250	500	235

NOTE - All air data measured external to unit with dry coil and 1 inch non-pleated air filter in place. Electric heaters have no appreciable air resistance.

### CB(X)26UH-030-230-01 BLOWER PERFORMANCE

External Static Pressure		Air Volume at Specific Blower Taps			
		High		Low	
in. w.g.	Pa	cfm	L/s	cfm	L/s
.10	25	1350	610	1145	520
.20	50	1290	585	1090	495
.30	75	1225	555	1030	465
.40	100	1150	520	960	435
.50	125	1065	485	875	395
.60	125	965	455	775	365

NOTE - All air data measured external to unit with dry coil and 1 inch non-pleated air filter in place. Electric heaters have no appreciable air resistance.

### CB(X)26UH-042-230-01 BLOWER PERFORMANCE

External Static Pressure		Air Volume at Specific Blower Taps			
		High		Low	
in. w.g.	Pa	cfm	L/s	cfm	L/s
.10	25	1940	880	1785	810
.20	50	1845	835	1705	775
.30	75	1745	790	1615	730
.40	100	1630	740	1515	685
.50	125	1495	680	1400	635
.60	150	1330	630	1265	595

NOTE - All air data measured external to unit with dry coil and 1 inch non-pleated air filter in place. Electric heaters have no appreciable air resistance.

### CB(X)26UH-060-230-01 BLOWER PERFORMANCE

External Static Pressure		Air Volume at Specific Blower Taps			
		High		Low	
in. w.g.	Pa	cfm	L/s	cfm	L/s
.10	25	2160	980	2075	940
.20	50	2065	935	1985	900
.30	75	1960	890	1885	855
.40	100	1845	835	1775	805
.50	125	1710	775	1645	745
.60	150	1550	730	1495	705

NOTE - All air data measured external to unit with dry coil and 1 inch non-pleated air filter in place. Electric heaters have no appreciable air resistance.

### CB(X)26UH-024-230-01 BLOWER PERFORMANCE

External Static Pressure		Air Volume at Specific Blower Taps			
		High		Low	
in. w.g.	Pa	cfm	L/s	cfm	L/s
.10	25	1040	470	1000	455
.20	50	980	445	940	425
.30	75	905	410	870	395
.40	100	815	370	785	355
.50	125	705	320	680	310
.60	150	535	250	530	250

NOTE - All air data measured external to unit with dry coil and 1 inch non-pleated air filter in place. Electric heaters have no appreciable air resistance.

### CB(X)26UH-036-230-01 BLOWER PERFORMANCE

External Static Pressure		Air Volume at Specific Blower Taps			
		High		Low	
in. w.g.	Pa	cfm	L/s	cfm	L/s
.10	25	1560	705	1405	635
.20	50	1480	670	1340	610
.30	75	1390	630	1270	575
.40	100	1290	585	1185	540
.50	125	1170	530	1090	495
.60	150	1015	480	975	460

NOTE - All air data measured external to unit with dry coil and 1 inch non-pleated air filter in place. Electric heaters have no appreciable air resistance.

### CB(X)26UH-048-230-01 BLOWER PERFORMANCE

External Static Pressure		Air Volume at Specific Blower Taps			
		High		Low	
in. w.g.	Pa	cfm	L/s	cfm	L/s
.10	25	1945	880	1870	850
.20	50	1860	845	1790	810
.30	75	1765	800	1700	770
.40	100	1660	755	1600	725
.50	125	1540	700	1485	675
.60	150	1395	660	1350	635

NOTE - All air data measured external to unit with dry coil and 1 inch non-pleated air filter in place. Electric heaters have no appreciable air resistance.

The following tables pertain to the -01 build CB(X)26UH-0XX-(R)-230-01 — Applicable to units with a three speed motor with date of manufacture date code of January 2009 through January 2010:

NOTE - All air data measured external to unit with dry coil and 1 inch non-pleated air filter in place. Electric heaters have no appreciable air resistance.

**CBX26UH-018 BLOWER PERFORMANCE**

External Static Pressure		Air Volume at Specific Blower Taps					
		High		Medium		Low	
in. w.g.	Pa	cfm	L/s	cfm	L/s	cfm	L/s
0.10	25	1035	490	995	470	720	340
0.20	50	960	450	925	435	700	330
0.30	75	875	410	840	395	655	310
0.40	100	780	370	705	335	610	285
0.50	125	665	315	625	295	515	245

NOTE - All air data measured external to unit with dry coil and 1 inch non-pleated air filter in place. Electric heaters have no appreciable air resistance.

**CBX26UH-024 BLOWER PERFORMANCE**

External Static Pressure		Air Volume at Specific Blower Taps					
		High		Medium		Low	
in. w.g.	Pa	cfm	L/s	cfm	L/s	cfm	L/s
0.10	25	1035	490	995	470	720	340
0.20	50	960	450	925	435	700	330
0.30	75	875	410	840	395	655	310
0.40	100	780	370	705	335	610	285
0.50	125	665	315	625	295	515	245

NOTE - All air data measured external to unit with dry coil and 1 inch non-pleated air filter in place. Electric heaters have no appreciable air resistance.

**CBX26UH-030 BLOWER PERFORMANCE**

External Static Pressure		Air Volume at Specific Blower Taps					
		High		Medium		Low	
in. w.g.	Pa	cfm	L/s	cfm	L/s	cfm	L/s
0.10	25	1290	610	1060	500	930	440
0.20	50	1270	600	1045	490	915	430
0.30	75	1215	570	1015	480	890	420
0.40	100	1155	545	950	445	840	395
0.50	125	1045	490	840	395	735	350

NOTE - All air data measured external to unit with dry coil and 1 inch non-pleated air filter in place. Electric heaters have no appreciable air resistance.

**CBX26UH-036 BLOWER PERFORMANCE**

External Static Pressure		Air Volume at Specific Blower Taps					
		High		Medium		Low	
in. w.g.	Pa	cfm	L/s	cfm	L/s	cfm	L/s
0.10	25	1495	705	1355	640	1135	535
0.20	50	1470	695	1345	635	1120	530
0.30	75	1415	670	1315	620	1110	525
0.40	100	1335	630	1260	595	1080	510
0.50	125	1250	590	1090	515	995	470

NOTE - All air data measured external to unit with dry coil and 1 inch non-pleated air filter in place. Electric heaters have no appreciable air resistance.

**CBX26UH-037 BLOWER PERFORMANCE**

External Static Pressure		Air Volume at Specific Blower Taps					
		High		Medium		Low	
in. w.g.	Pa	cfm	L/s	cfm	L/s	cfm	L/s
.10	25	1625	765	1460	690	1220	575
.20	50	1610	760	1450	685	1215	575
.30	75	1565	740	1440	680	1200	566
.40	100	1540	725	1405	665	1165	550
.50	125	1440	680	1320	625	1095	515
.60	150	1385	655	1205	570	1022	480

NOTE - All air data measured external to unit with dry coil and 1 inch non-pleated air filter in place. Electric heaters have no appreciable air resistance.

**CBX26UH-042 BLOWER PERFORMANCE**

External Static Pressure		Air Volume at Specific Blower Taps					
		High		Medium		Low	
in. w.g.	Pa	cfm	L/s	cfm	L/s	cfm	L/s
0.10	25	1540	725	1405	665	1200	565
0.20	50	1530	720	1415	665	1190	565
0.30	75	1505	710	1385	655	1160	545
0.40	100	1385	655	1305	615	1115	525
0.50	125	1255	590	1190	565	1000	470

NOTE - All air data measured external to unit with dry coil and 1 inch non-pleated air filter in place. Electric heaters have no appreciable air resistance.

**CBX26UH-048 BLOWER PERFORMANCE**

External Static Pressure		Air Volume at Specific Blower Taps					
		High		Medium		Low	
in. w.g.	Pa	cfm	L/s	cfm	L/s	cfm	L/s
0.10	25	1885	890	1760	830	1595	750
0.20	50	1820	860	1710	805	1580	745
0.30	75	1740	820	1635	770	1525	720
0.40	100	1605	755	1540	725	1445	680
0.50	125	1445	680	1395	660	1320	620

NOTE - All air data measured external to unit with dry coil and 1 inch non-pleated air filter in place. Electric heaters have no appreciable air resistance.

**CBX26UH-060 BLOWER PERFORMANCE**

External Static Pressure		Air Volume at Specific Blower Taps					
		High		Medium		Low	
in. w.g.	Pa	cfm	L/s	cfm	L/s	cfm	L/s
0.10	25	2110	995	2065	975	1780	840
0.20	50	2065	975	1960	925	1755	830
0.30	75	1950	920	1860	880	1670	790
0.40	100	1770	835	1715	810	1555	735
0.50	125	1585	750	1475	695	1395	655

NOTE - All air data measured external to unit with dry coil and 1 inch non-pleated air filter in place. Electric heaters have no appreciable air resistance.

The following tables pertain to the -02 build CB(X)26UH-0XX-(R)-230-02:

Only the 3.5, 4 and 5 ton units had CFM specifications changed for -02 build. Use previous section CFM tables for all other sizes.

NOTE - All air data measured external to unit with dry coil and 1 inch non-pleated air filter in place. Electric heaters have no appreciable air resistance.

CB(X)26UH-042-230-2 BLOWER PERFORMANCE							
External Static Pressure		Air Volume at Specific Blower Taps					
		High		Medium		Low	
w.g	Pa	cfm	L/s	cfm	L/s	cfm	L/s
0.10	25	1803	851	1707	806	1603	757
0.20	50	1749	825	1635	772	1542	728
0.30	75	1665	786	1561	737	1474	696
0.35	87	1614	762	1530	722	1449	684
0.40	100	1545	729	1482	699	1407	664
0.45	112	1474	696	1416	668	1373	648
0.50	125	1416	668	1373	648	1301	614
0.55	137	1373	648	1292	610	1254	592

CB(X)26UH-060-230-2 BLOWER PERFORMANCE							
External Static Pressure		Air Volume at Specific Blower Taps					
		High		Medium		Low	
w.g	Pa	cfm	L/s	cfm	L/s	cfm	L/s
0.10	25	2276	1074	2080	982	1734	818
0.20	50	2184	1030	2038	962	1712	808
0.30	75	2092	987	1971	930	1688	797
0.35	87	2020	953	1920	906	1673	790
0.40	100	1958	924	1855	875	1644	776
0.45	112	1881	888	1801	850	1567	740
0.50	125	1842	869	1717	810	1503	709
0.55	137	1675	791	1583	747	1418	669

CB(X)26UH-048-230-2 BLOWER PERFORMANCE							
External Static Pressure		Air Volume at Specific Blower Taps					
		High		Medium		Low	
w.g	Pa	cfm	L/s	cfm	L/s	cfm	L/s
0.10	25	2181	1029	2158	1018	1743	823
0.20	50	2112	997	1943	917	1700	802
0.30	75	1918	905	1826	862	1641	774
0.35	87	1839	868	1771	836	1596	753
0.40	100	1771	836	1700	802	1565	739
0.45	112	1700	802	1657	782	1517	716
0.50	125	1642	775	1581	746	1451	685
0.55	137	1549	731	1517	716	1399	660

# CB26UH AND CBX26UH PARTS ARRANGEMENT

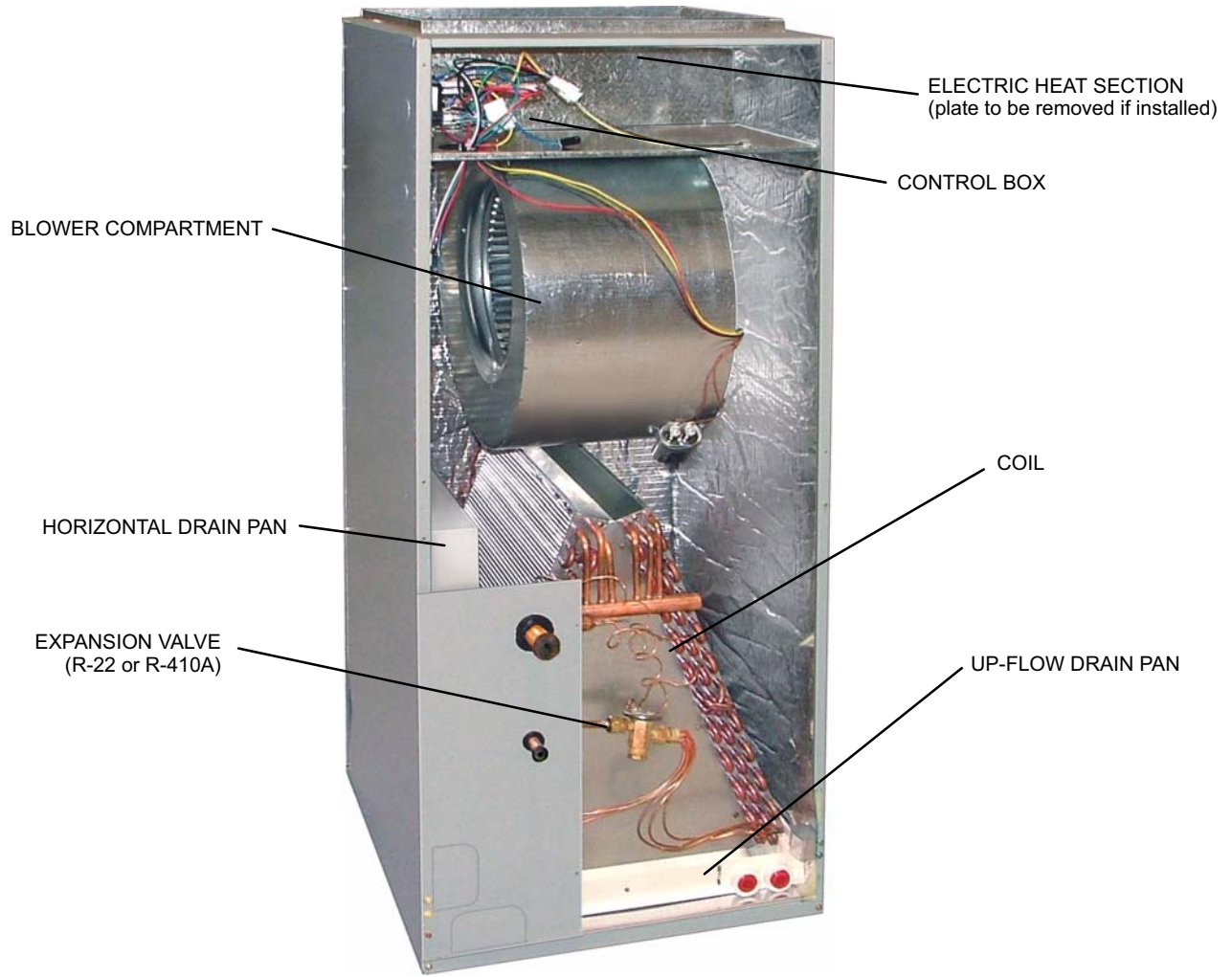

FIGURE 1



## I-APPLICATION

### **⚠ CAUTION**

Electrostatic discharge can affect electronic components. Take precautions during unit installation and service to protect the unit's electronic controls. Precautions will help to avoid control exposure to electrostatic discharge by putting the unit, the control and the technician at the same electrostatic potential. Neutralize electrostatic charge by touching hand and all tools on an unpainted unit surface before performing any service procedure.

All major blower coil components must be matched according to Lennox recommendations for the unit to be covered under warranty. Refer to the Engineering Handbook for approved system matchups. A misapplied system will cause erratic operation and can result in early unit failure. The units come with factory installed check and expansion valve for all applications. The TXV valve has been installed internally for a cleaner installation and is accessible if required.

## II-UNIT COMPONENTS

### A-Control Box

The CB26UH and CBX26UH control box is located above the blower section shown in figure 1. Line voltage and electric heat connections are made in the control box. Optional electric heat fits through an opening located in the center of the control box. When electric heat is not used, cover plates cover the opening. The electric heat control arrangement is detailed in the electric heat section of this manual.

### 1-Transformer

All CB26UH and CBX26UH series units use a single line voltage to 24VAC transformer mounted in the control box. The transformer supplies power to the control circuits in the indoor and outdoor unit. Transformers are rated at 40VA. 208/240VAC single phase transformers use two primary voltage taps as shown in figure 2.

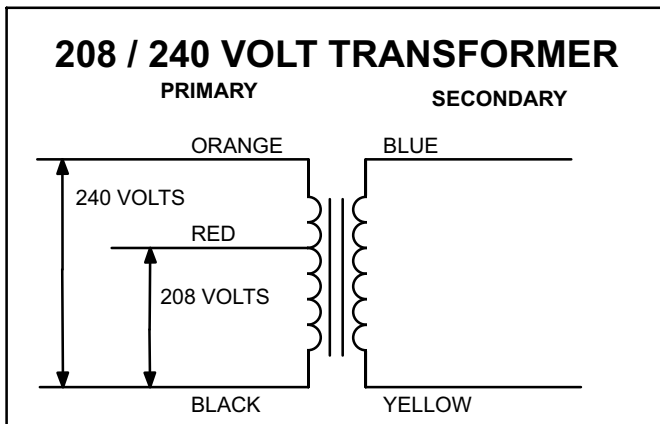

FIGURE 2

## 2-Blower Relay

All CB26UH and CBX26UH units use a double-pole single-throw (DPST) switch relay to energize the blower motor. The relay coil is energized by blower demand from indoor thermostat. When the coil is energized, a set of normally open (N.O.) contacts closes to energize the blower motor on cooling speed. When de-energized, a set of normally closed (N.C.) contacts allows the electric heat relay to energize the blower on heating speed (refer to unit wiring diagram).

## 3-Time Delay Relay

The blower time delay is a 24 volt N.O. relay wired to the blower relay. See unit diagram. The delay is between 10 and 60 seconds and delays the blower on and off time in the cooling cycle.

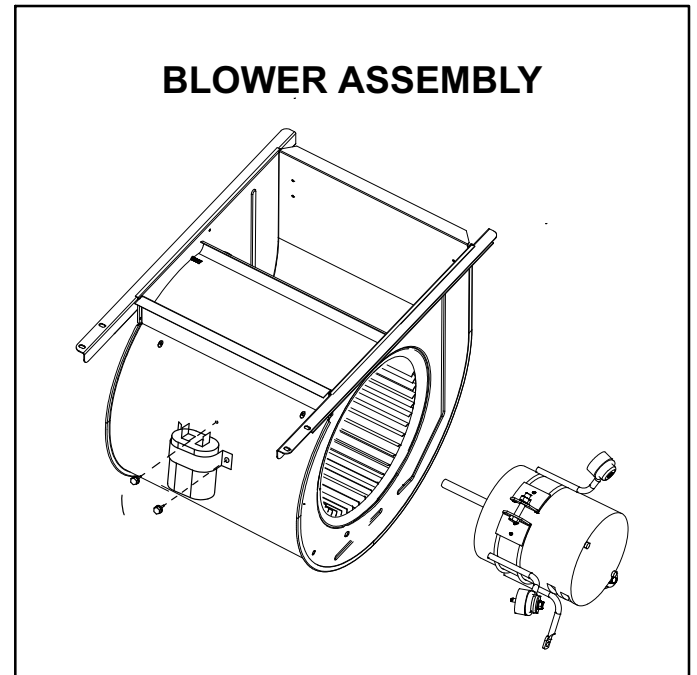

FIGURE 3

## B-Blower Motor (B3)

CB26UH and CBX26UH units use single phase direct drive blower motors with a run capacitor. Figure 3 shows the parts arrangement. All motors have two speed taps. Typically, the high speed tap is energized during normal operation.

All units are factory wired for the high blower speed for heat pump and cooling applications with or without electric heat. No field wiring is required. The wiring diagrams show factory set blower speeds.

## 1-Blower Motor Capacitor

All CB26UH and CBX26UH series units use single phase direct drive motors with a run capacitor. The run capacitor is mounted on the blower housing. See figure 3. Capacitor ratings are shown on side of capacitor and indoor blower motor nameplate.

## C-Coil

CB26UH and CBX26UH units have dual slab coils arranged in an **A** configuration. Each coil has two or three rows of copper tubes fitted with ripple-edged aluminum fins. An expansion valve, feeds multiple parallel circuits through the coils. The coil is designed to easily slide out of the unit cabinet.

## D-Plastic Drain Pans

Drain pans are provided and installed on the CB26UH and CBX26UH, The drain pans are made from fiberglass filled plastic.

## III-OPTIONAL ECB26 ELECTRIC HEAT

### A-Matchups and Ratings

Tables 2 through 5 show all approved CB26UH and CBX26UH to ECB26 matchups and electrical ratings.

### B-Electric Heat Components

ECB26 parts arrangement is shown in figure 4. All electric heat sections consist of components mounted to the electric heat vestibule panel and electric heating elements exposed directly to the airstream. 208/230V electric heat sections may be equipped with circuit breakers. The circuit breakers are designated by CB in the model number.

#### 1 - Electric Heat Sequencer Relays 1 and 2

Relays are N.O. sequencer relays with a resistive element for a coil and a bi-metal disk which actuates the contacts. The relays are located on the electric heat vestibule panel and are energized by a 24V heating demand (W1 and W2) via jack/plug 2. When energized, the internal resistance heats the bi-metal disk causing the contacts to close. When the relay is de-energized, the disk cools and the contacts open. The relays energize different stages of heat, as well as the blower. The blower is always first on and last off.

#### 2 - Primary Limits 1, 2, 3 & 4

The primary limits are located on the electric heat vestibule panel and exposed directly to the airstream through an opening in the panel. They are SPST N.C. auto-reset limits. The limits are factory set and not adjustable.

#### 208/230 Volt Electric Heat Sections

Each stage of the 208/230 electric heat is protected by a primary high temperature limit. Each stage uses the same style of limit. The primary limit is wired in series with a heat element. When either limit opens, the corresponding heat element is de-energized. All other heating elements remain energized. The primary high temperature limit opens at  $150^{\circ}\text{F} \pm 5^{\circ}\text{F}$  ( $65.5^{\circ}\text{C} \pm 2.8^{\circ}\text{C}$ ) on a temperature rise and automatically resets at  $110^{\circ}\text{F} \pm 9^{\circ}\text{F}$  ( $43.3^{\circ}\text{C} \pm 5.0^{\circ}\text{C}$ ) on a temperature fall.

#### 3 - Circuit Breaker

Line voltage connections are made to circuit breakers in the electric heat sections with circuit breakers (designated by CB in the model numbers). Table 1 shows the amp rating for each circuit breaker used. Single phase electric heat uses two pole circuit breakers.

TABLE 1

ECB29 CIRCUIT BREAKERS			
UNIT	CB1 AMPS	CB2 AMPS	CB3 AMPS
ECB26-5CB-1 (P)	30 AMP	---	---
ECB26-7CB-1 (P)	45 AMP	---	---
ECB26-10CB-1 (P)	60 AMP	---	---
ECB26-15CB-1 (P)	60 AMP	30 AMP	---
ECB26-20CB-1 (P)	60 AMP	60 AMP	---

## 4 - Heating Elements

Heating elements are composed of helix wound bare nichrome wire exposed directly to the airstream. The elements are supported by insulators mounted to the wire frame. For single phase applications, one element is used per stage. Each stage is energized independently by the corresponding relay located on the electric heat vestibule panel. Once energized, heat transfer is instantaneous. High temperature protection is provided by primary high temperature limits.

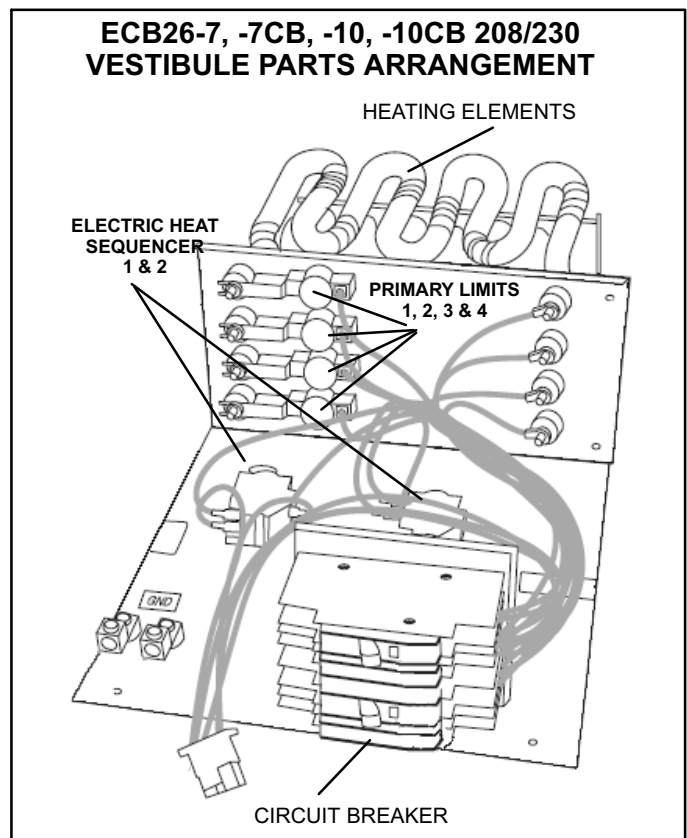

FIGURE 4

**TABLE 2**

SINGLE PHASE		CB(X)26UH-018 / CBX26UH-024									
		Input			Blower Motor Full Load Amps	<sup>2</sup> Minimum Circuit Ampacity		<sup>3</sup> Maximum Overcurrent Protection		Single Point Power Source	
		Volt	kW	1 Btuh		Ckt 1	Ckt 2	Ckt 1	Ckt 2	<sup>2</sup> Minimum Circuit Ampacity	<sup>3</sup> Maximum Overcurrent Protection
2.5 kW	ECB26-2.5 (19W05) Terminal Block	208	1.9	6,400	1.5	13.3	---	15	---	---	---
		220	2.1	7,200	1.4	13.7	---	15	---	---	---
		230	2.3	7,800	1.4	14.3	---	15	---	---	---
		240	2.5	8,500	1.4	14.8	---	15	---	---	---
5 kW	ECB26-5 (99M64) Terminal Block	208	3.8	12,800	1.5	24.7	---	<sup>4</sup> 25	---	---	---
		220	4.2	14,300	1.4	25.6	---	30	---	---	---
	ECB26-5CB (99M65) Circuit Breaker	230	4.6	15,700	1.4	26.8	---	30	---	---	---
		240	5.0	17,100	1.4	27.8	---	30	---	---	---
7.5 kW	ECB26-7 (99M67) Terminal Block	208	5.6	19,200	1.5	35.5	---	<sup>4</sup> 40	---	---	---
		220	6.3	21,500	1.4	37.5	---	<sup>4</sup> 40	---	---	---
	ECB26-7CB (99M66) Circuit Breaker	230	6.9	23,500	1.4	39.3	---	<sup>4</sup> 40	---	---	---
		240	7.5	25,600	1.4	40.8	---	45	---	---	---
10 kW	ECB26-10 (99M68) Terminal Block	208	7.5	25,600	1.5	46.9	---	<sup>4</sup> 50	---	---	---
		220	8.4	28,700	1.4	49.5	---	<sup>4</sup> 50	---	---	---
	ECB26-10CB (99M69) Circuit Breaker	230	9.2	31,400	1.4	51.8	---	60	---	---	---
		240	10.0	34,100	1.4	53.8	---	60	---	---	---

NOTE - Circuit 1 Minimum Circuit Ampacity includes the Blower Motor Full Load Amps.

1 Electric heater capacity only - does not include additional blower motor heat capacity.

2 Refer to National or Canadian Electrical Code manual to determine wire, fuse and disconnect size requirements. Use wires suitable for at least 167°F.

3 HACR type breaker or fuse.

4 Bold indicates that the circuit breaker on "CB" circuit breaker models must be replaced with size shown.

**TABLE 3**

SINGLE PHASE		CB(X)26UH-030									
		Input			Blower Motor Full Load Amps	<sup>2</sup> Minimum Circuit Ampacity		<sup>3</sup> Maximum Overcurrent Protection		Single Point Power Source	
		Volt	kW	<sup>1</sup> Btuh		Ckt 1	Ckt 2	Ckt 1	Ckt 2	<sup>2</sup> Minimum Circuit Ampacity	<sup>3</sup> Maximum Overcurrent Protection
2.5 kW	ECB26-2.5 (19W05) Terminal Block	208	1.9	6,400	1.6	13.4	---	15	---	---	---
		220	2.1	7,200	1.5	13.8	---	15	---	---	---
		230	2.3	7,800	1.5	14.4	---	15	---	---	---
		240	2.5	8,500	1.5	14.9	---	15	---	---	---
5 kW	ECB26-5 (99M64) Terminal Block	208	3.8	12,800	1.6	24.8	---	<sup>4</sup> 25	---	---	---
		220	4.2	14,300	1.5	25.7	---	30	---	---	---
	ECB26-5CB (99M65) Circuit Breaker	230	4.6	15,700	1.5	26.9	---	30	---	---	---
		240	5.0	17,100	1.5	27.9	---	30	---	---	---
7.5 kW	ECB26-7 (99M67) Terminal Block	208	5.6	19,200	1.6	35.7	---	<sup>4</sup> 40	---	---	---
		220	6.3	21,500	1.5	37.7	---	<sup>4</sup> 40	---	---	---
	ECB26-7CB (99M66) Circuit Breaker	230	6.9	23,500	1.5	39.4	---	<sup>4</sup> 40	---	---	---
		240	7.5	25,600	1.5	40.9	---	45	---	---	---
10 kW	ECB26-10 (99M68) Terminal Block	208	7.5	25,600	1.6	47.1	---	<sup>4</sup> 50	---	---	---
		220	8.4	28,700	1.5	49.6	---	<sup>4</sup> 50	---	---	---
	ECB26-10CB (99M69) Circuit Breaker	230	9.2	31,400	1.5	51.9	---	60	---	---	---
		240	10.0	34,100	1.5	54.0	---	60	---	---	---
12.5 kW	ECB26-12.5CB (19W00) Circuit Breaker	208	9.4	32,000	1.6	35.8	22.6	<sup>4</sup> 40	<sup>4</sup> 25	59	60
		220	10.5	35,800	1.5	37.7	23.9	<sup>4</sup> 40	<sup>4</sup> 25	62	70
		230	11.5	39,200	1.5	39.3	24.9	<sup>4</sup> 40	<sup>4</sup> 25	65	70
		240	12.5	42,600	1.5	40.9	26.0	45	30	67	70
15 kW	ECB26-15CB (99M70) Circuit Breaker	208	11.3	38,400	1.6	47.1	22.6	<sup>4</sup> 50	<sup>4</sup> 25	70	70
		220	12.6	43,000	1.5	49.8	23.9	<sup>4</sup> 50	<sup>4</sup> 25	74	80
		230	13.5	47,000	1.5	51.8	24.9	60	<sup>4</sup> 25	77	80
		240	15.0	51,200	1.5	54.0	26.0	60	30	80	80

NOTE - Circuit 1 Minimum Circuit Ampacity includes the Blower Motor Full Load Amps.

1 Electric heater capacity only - does not include additional blower motor heat capacity.

2 Refer to National or Canadian Electrical Code manual to determine wire, fuse and disconnect size requirements. Use wires suitable for at least 167°F.

3 HACR type breaker or fuse.

4 Bold indicates that the circuit breaker on "CB" circuit breaker models must be replaced with size shown.

**TABLE 4**

SINGLE PHASE		CB(X)26UH-036 / CBX26UH-037											
		Description			Input		Blower Motor Full Load Amps	<sup>2</sup> Minimum Circuit Ampacity		<sup>3</sup> Maximum Overcurrent Protection		Single Point Power Source	
		Volt	kW	<sup>1</sup> Btuh	Ckt 1	Ckt 2		Ckt 1	Ckt 2	<sup>2</sup> Minimum Circuit Ampacity	<sup>3</sup> Maximum Overcurrent Protection		
2.5 kW	ECB26-2.5 (19W05) Terminal Block	208	1.9	6,400	2.1	14.0	---	15	---	---	---		
		220	2.1	7,200	2.0	14.4	---	15	---	---	---		
		230	2.3	7,800	2.0	15.0	---	15	---	---	---		
		240	2.5	8,500	2.0	15.5	---	20	---	---	---		
5 kW	ECB26-5 (99M64) Terminal Block	208	3.8	12,800	2.1	25.5	---	30	---	---	---		
		220	4.2	14,300	2.0	26.4	---	30	---	---	---		
	ECB26-5CB (99M65) Circuit Breaker	230	4.6	15,700	2.0	27.5	---	30	---	---	---		
		240	5.0	17,100	2.0	28.5	---	30	---	---	---		
7.5 kW	ECB26-7 (99M67) Terminal Block	208	5.6	19,200	2.1	36.3	---	<sup>4</sup> 40	---	---	---		
		220	6.3	21,500	2.0	38.3	---	<sup>4</sup> 40	---	---	---		
	ECB26-7CB (99M66) Circuit Breaker	230	6.9	23,500	2.0	40.0	---	<sup>4</sup> 40	---	---	---		
		240	7.5	25,600	2.0	41.6	---	45	---	---	---		
10 kW	ECB26-10 (99M68) Terminal Block	208	7.5	25,600	2.1	47.7	---	<sup>4</sup> 50	---	---	---		
		220	8.4	28,700	2.0	50.2	---	60	---	---	---		
	ECB26-10CB (99M69) Circuit Breaker	230	9.2	31,400	2.0	52.5	---	60	---	---	---		
		240	10.0	34,100	2.0	54.6	---	60	---	---	---		
12.5 kW	ECB26-12.5CB (19W00) Circuit Breaker	208	9.4	32,000	2.1	36.4	22.6	<sup>4</sup> 40	30	59	60		
		220	10.5	35,800	2.0	38.3	23.9	<sup>4</sup> 40	30	63	70		
		230	11.5	39,200	2.0	39.9	24.9	<sup>4</sup> 40	30	65	70		
		240	12.5	42,600	2.0	41.6	26.0	45	30	68	70		
15 kW	ECB26-15CB (99M70) Circuit Breaker	208	11.3	38,400	2.1	47.8	22.6	<sup>4</sup> 50	30	71	80		
		220	12.6	43,000	2.0	50.5	23.9	60	30	75	80		
		230	13.5	47,000	2.0	52.4	24.9	60	30	78	80		
		240	15.0	51,200	2.0	54.6	26.0	60	30	81	90		

NOTE - Circuit 1 Minimum Circuit Ampacity includes the Blower Motor Full Load Amps.

<sup>1</sup> Electric heater capacity only - does not include additional blower motor heat capacity.

<sup>2</sup> Refer to National or Canadian Electrical Code manual to determine wire, fuse and disconnect size requirements. Use wires suitable for at least 167°F.

<sup>3</sup> HACR type breaker or fuse.

<sup>4</sup> Bold indicates that the circuit breaker on "CB" circuit breaker models must be replaced with size shown.

**TABLE 5**

SINGLE PHASE		CB(X)26UH-042									
		Input			Blower Motor Full Load Amps	<sup>2</sup> Minimum Circuit Ampacity		<sup>3</sup> Maximum Overcurrent Protection		Single Point Power Source	
		Volt	kW	<sup>1</sup> Btuh		Ckt 1	Ckt 2	Ckt 1	Ckt 2	<sup>2</sup> Minimum Circuit Ampacity	<sup>3</sup> Maximum Overcurrent Protection
2.5 kW	ECB26-2.5 (19W05) Terminal Block	208	1.9	6,400	2.6	14.7	---	15	---	---	---
		220	2.1	7,200	2.5	15.1	---	20	---	---	---
		230	2.3	7,800	2.5	15.6	---	20	---	---	---
		240	2.5	8,500	2.5	16.1	---	20	---	---	---
5 kW	ECB26-5 (99M64) Terminal Block	208	3.8	12,800	2.6	26.1	---	30	---	---	---
		220	4.2	14,300	2.5	27.0	---	30	---	---	---
	ECB26-5CB (99M65) Circuit Breaker	230	4.6	15,700	2.5	28.1	---	30	---	---	---
		240	5.0	17,100	2.5	29.2	---	30	---	---	---
7.5 kW	ECB26-7 (99M67) Terminal Block	208	5.6	19,200	2.6	36.9	---	<sup>4</sup> 40	---	---	---
		220	6.3	21,500	2.5	38.9	---	<sup>4</sup> 40	---	---	---
	ECB26-7CB (99M66) Circuit Breaker	230	6.9	23,500	2.5	40.6	---	45	---	---	---
		240	7.5	25,600	2.5	42.2	---	45	---	---	---
10 kW	ECB26-10 (99M68) Terminal Block	208	7.5	25,600	2.6	48.3	---	<sup>4</sup> 50	---	---	---
		220	8.4	28,700	2.5	50.9	---	60	---	---	---
	ECB26-10CB (99M69) Circuit Breaker	230	9.2	31,400	2.5	53.1	---	60	---	---	---
		240	10.0	34,100	2.5	55.2	---	60	---	---	---
12.5 kW	ECB26-12.5CB (19W00) Circuit Breaker	208	9.4	32,000	2.6	37.1	22.6	<sup>4</sup> 40	<sup>4</sup> 25	60	60
		220	10.5	35,800	2.5	38.9	23.9	<sup>4</sup> 40	<sup>4</sup> 25	63	70
		230	11.5	39,200	2.5	40.5	24.9	45	<sup>4</sup> 25	66	70
		240	12.5	42,600	2.5	42.2	26.0	45	30	69	70
15 kW	ECB26-15CB (99M70) Circuit Breaker	208	11.3	38,400	2.6	48.4	22.6	<sup>4</sup> 50	25	71	80
		220	12.6	43,000	2.5	51.1	23.9	60	<sup>4</sup> 25	75	80
		230	13.5	47,000	2.5	53.0	24.9	60	<sup>4</sup> 25	78	80
		240	15.0	51,200	2.5	55.2	26.0	60	30	82	90

NOTE - Circuit 1 Minimum Circuit Ampacity includes the Blower Motor Full Load Amps.

1 Electric heater capacity only - does not include additional blower motor heat capacity.

2 Refer to National or Canadian Electrical Code manual to determine wire, fuse and disconnect size requirements. Use wires suitable for at least 167°F.

3 HACR type breaker or fuse.

4 Bold indicates that the circuit breaker on "CB" circuit breaker models must be replaced with size shown.

**TABLE 6**

SINGLE PHASE		CB(X)26UH-048-060									
Description		Input			Blower Motor Full Load Amps (240V)	<sup>2</sup> Minimum Circuit Ampacity		<sup>3</sup> Maximum Overcurrent Protection		Single Point Power Source	
		Volt	kW	<sup>1</sup> Btuh		Ckt 1	Ckt 2	Ckt 1	Ckt 2	<sup>2</sup> Minimum Circuit Ampacity	<sup>3</sup> Maximum Overcurrent Protection
2.5 kW	ECB26-2.5 (19W05) Terminal Block	208	1.9	6,400	4.1	16.5	---	20	---	---	---
		220	2.1	7,200	3.9	16.8	---	20	---	---	---
		230	2.3	7,800	3.9	17.4	---	20	---	---	---
		240	2.5	8,500	3.9	17.9	---	20	---	---	---
5 kW	ECB26-5 (99M64) Terminal Block	208	3.8	12,800	4.1	28.0	---	30	---	---	---
		220	4.2	14,300	3.9	28.7	---	30	---	---	---
	ECB26-5CB (99M65) Circuit Breaker	230	4.6	15,700	3.9	29.9	---	30	---	---	---
		240	5.0	17,100	3.9	30.9	---	<sup>4</sup> 35	---	---	---
7.5 kW	ECB26-7 (99M67) Terminal Block	208	5.6	19,200	4.1	38.8	---	<sup>4</sup> 40	---	---	---
		220	6.3	21,500	3.9	40.7	---	45	---	---	---
	ECB26-7CB (99M66) Circuit Breaker	230	6.9	23,500	3.9	42.4	---	45	---	---	---
		240	7.5	25,600	3.9	43.9	---	45	---	---	---
10 kW	ECB26-10 (99M68) Terminal Block	208	7.5	25,600	4.1	50.2	---	60	---	---	---
		220	8.4	28,700	3.9	52.6	---	60	---	---	---
	ECB26-10CB (99M69) Circuit Breaker	230	9.2	31,400	3.9	54.9	---	60	---	---	---
		240	10.0	34,100	3.9	57.0	---	60	---	---	---
12.5 kW	ECB26-12.5CB (19W00) Circuit Breaker	208	9.4	32,000	4.1	38.9	22.6	<sup>4</sup> 40	25	62	70
		220	10.5	35,800	3.9	40.7	23.9	45	25	65	70
		230	11.5	39,200	3.9	42.3	24.9	45	25	68	70
		240	12.5	42,600	3.9	43.9	26.0	45	30	70	70
15 kW	ECB26-15CB (99M70) Circuit Breaker	208	11.3	38,400	4.1	50.3	22.6	60	25	73	80
		220	12.6	43,000	3.9	52.8	23.9	60	25	77	80
		230	13.5	47,000	3.9	54.8	24.9	60	25	80	80
		240	15.0	51,200	3.9	57.0	26.0	60	30	83	90
20 kW	ECB26-20CB (99M71) Circuit Breaker	208	15.0	51,200	4.1	50.3	45.1	60	<sup>4</sup> 50	96	100
		220	16.8	57,300	3.9	52.8	48.0	60	<sup>4</sup> 50	101	110
		230	18.4	62,700	3.9	54.8	49.9	60	<sup>4</sup> 50	105	110
		240	20.0	68,200	3.9	57.0	52.1	60	60	110	110

NOTE - Circuit 1 Minimum Circuit Ampacity includes the Blower Motor Full Load Amps.

1 Electric heater capacity only - does not include additional blower motor heat capacity.

2 Refer to National or Canadian Electrical Code manual to determine wire, fuse and disconnect size requirements. Use wires suitable for at least 167°F.

3 HACR type breaker or fuse.

4 Bold indicates that the circuit breaker on "CB" circuit breaker models must be replaced with size shown.

## IV-CONFIGURATION MODIFICATIONS

CB26UH and CBX26UH units are factory-assembled and configured for installation in upflow or horizontal left-hand air discharge applications. A kit is available to convert units for downflow applications. See OPTIONAL ACCESSORIES at the front of this manual.

If the unit needs to be modified from its original configuration, use the following procedures. All procedures assume the unit has not been modified from the factory.

### General Information

## **⚠ WARNING**

**Improper installation, adjustment, alteration, service or maintenance can cause property damage, personal injury or loss of life. Installation and service must be performed by a qualified installer or service agency.**

Each unit consists of a blower assembly, refrigerant coil, and controls, in an insulated galvanized steel factory finished enclosure. Knockouts are provided for electrical wiring entrance.

For ease in installation, it is best to make any necessary coil configuration changes before setting air handler in place.

If a filter is to be installed at the air handler, a filter rack must be formed using factory-supplied flanges. Lay the unit on its back and pry out the filter rack tabs as shown in figure 5.

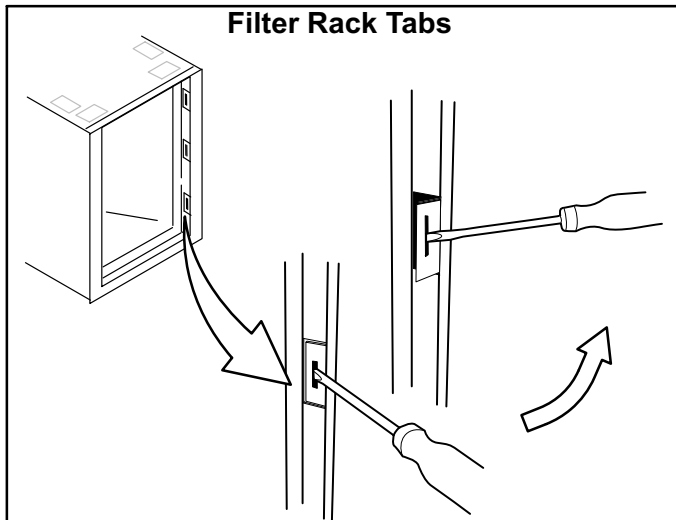

FIGURE 5

### Upflow Application

1. The air handler must be supported on the bottom only and set on solid floor or field-supplied support frame. Securely attach the air handler to the floor or support frame.
2. If installing a unit in an upflow application, remove the horizontal drain pan; it is not required in upflow air discharge installations.
3. Place the unit in desired location. Set unit so that it is level. Connect return and supply air plenums as required using sheet metal screws.

4. Install units that have no return air plenum on a stand that is at least 14" from the floor. This will allow proper air return.

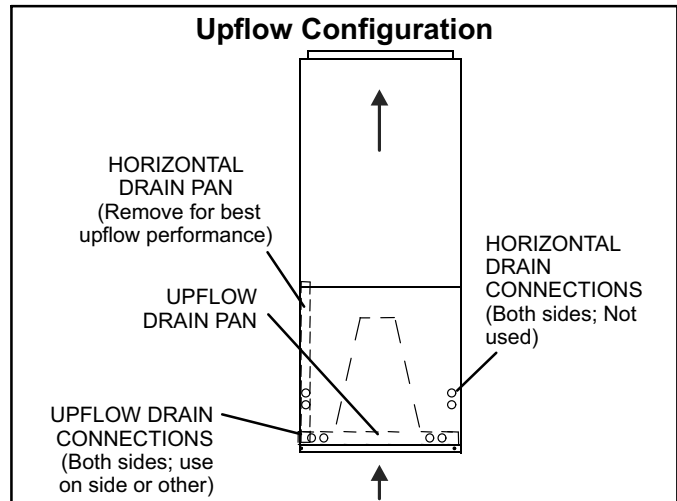

FIGURE 6

### Horizontal Applications

*NOTE - When the unit is installed in horizontal applications, a secondary drain pan is recommended. Refer to local codes.*

This unit may be installed in left-hand or right-hand air discharge horizontal applications. Adequate support must be provided to ensure cabinet integrity. Ensure that there is adequate room to remove service and access panels if installing in the horizontal position.

1. Determine whether left-hand or right-hand air discharge is required. If right-hand is required, perform *Right-Hand Discharge Modification*. See next page.
2. Determine knockouts required for drain line connections.
3. With access door removed, knock out drain line opening for installing drain lines.
4. Set unit so that it is sloped (up to 1/4 inch) toward the drain pan end of the unit.
5. The horizontal configuration is shown in figure 7.

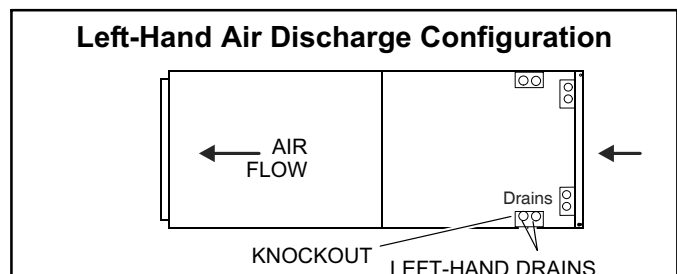

FIGURE 7

6. If the unit is suspended, the entire length of the cabinet must be supported. If you use a chain or strap, use a piece of angle iron or sheet metal attached to the unit (either above or below) to support the length of the cabinet. Use securing screws no longer than 1/2 inch to avoid damaging the coil or filter. See figure 8. Use sheet metal screws to connect the return and supply air plenums as required.



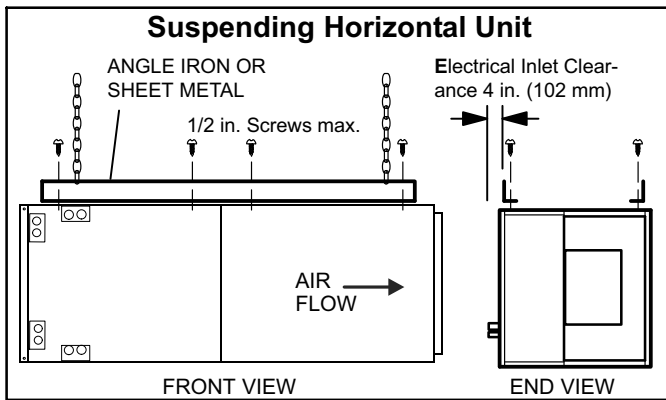

FIGURE 8

## ⚠ IMPORTANT

When removing the coil, there is possible danger of equipment damage and personal injury. Be careful when removing the coil assembly from a unit installed in right- or left-hand applications. The coil may tip into the drain pan once it is clear of the cabinet. Support the coil when removing it.

### Right-Hand Air Discharge Modification

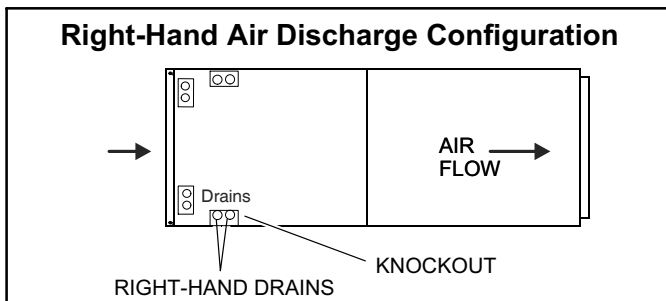

FIGURE 9

For horizontal right-hand air discharge, the following field modifications are required.

1. Remove and set aside blower and coil access covers.
2. Remove the coil support bracket (see detail A, figure 10).
3. Remove coil assembly, bottom drain pan and horizontal drain pan as one assembly from the air handler.
4. Remove the drain plugs from back of horizontal drain pan and reinstall in the front holes.
5. Remove two screws and blowoff prevention bracket (BP BRACKET in figure 10). Rotate the bracket 180° and reinstall using the same screws.
6. Move horizontal drain pan to the opposite side of the coil. Plugged drain holes will now be toward the back of the unit (see figure 11).
7. Re-install modified coil/drain pan assembly in air handler in the same orientation as before.
8. Install the coil support bracket on the opposite side of the air handler (detail B, figure 10)..

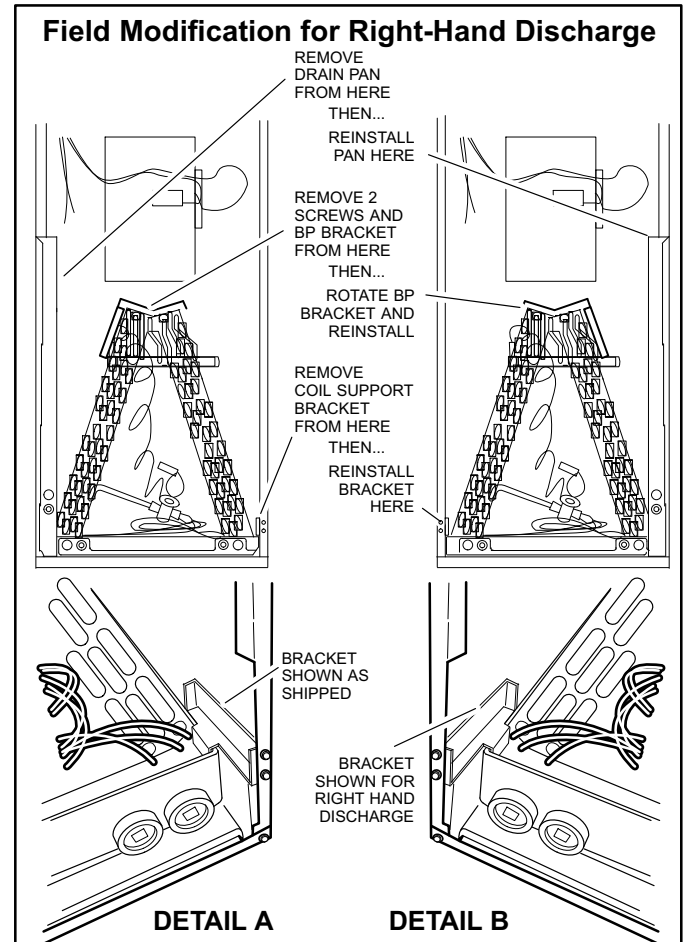

FIGURE 10

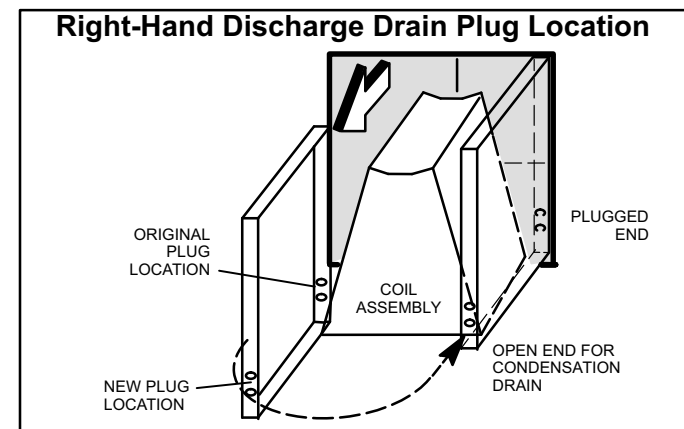

FIGURE 11

### Install Condensate Drain

The air handler is provided with 3/4" NPT condensate drain connections.

## ⚠ IMPORTANT

A field-fabricated secondary drain pan, with a drain pipe to the outside of the building, is required in all installations over a finished living space or in any area that may be damaged by overflow from the main drain pan. In some localities, local codes may require an secondary drain pan for any horizontal installation.

Make sure the unit is sloped (up to 1/4 inch) so that the drain pan will empty completely without water standing in the pan. See figure 12.

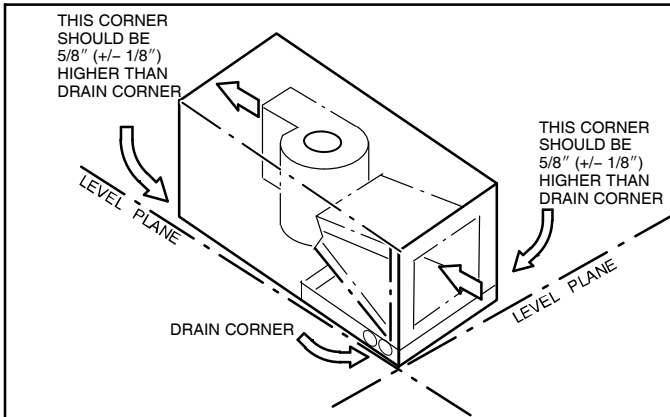

**FIGURE 12**

1. Remove the appropriate drain knockouts. If necessary, remove the indoor coil assembly from the cabinet.
2. Connect primary drain line connection to the primary drain pan connection. The primary drain connection is flush with the bottom of the inside of the pan. Secondary connection is raised above the bottom of the inside of the pan.

*NOTE - When making drain fitting connections to the drain pan, hand tighten the fitting and use a sealant. Overtightening the fittings can split connections on the drain pan.*

3. Secondary drain connections, if used, should be connected to a separate drainage system. Run the secondary drain line to a place where the occupant would be sure to notice any drainage from the drain.
4. Install a 3" trap in both the primary and secondary drain lines as close to the unit as practical (see figure 13). Make sure the top of the trap is below the connection to the drain pan to allow complete drainage of the pan.

5. Route the drain line to the outside or to an appropriate drain. Drain lines must be installed so they do not block service access to the front of the air handler. A 24" clearance is required for filter, coil, or blower removal and service access.

*NOTE - Check local codes before connecting the drain line to an existing drainage system.*

6. Insulate the drain lines where sweating could cause water damage.

### Test Condensate Drain

Test the drain pan and drain line after installation:

1. Pour several quarts of water into drain pan, enough to fill drain trap and line.
2. Check to make sure the drain pan is draining completely, no leaks are found in drain line fittings, and water is draining from the end of the primary drain line.
3. Correct any leaks found.

## V-START-UP - OPERATION

### A-Preliminary and Seasonal Checks

- 1- Make sure the unit is installed in accordance with the installation instructions.
- 2- Inspect electrical wiring, both field and factory installed for loose connections. Tighten as required.
- 3- Check voltage at disconnect switch. Voltage must be within range listed on the nameplate. If not, consult the power company and have voltage condition corrected before starting unit.
- 4- Check to ensure that refrigerant lines are in good condition and pipe insulation is intact.
- 5- Inspect condition of condensate drain pan and piping assembly. Disassemble and clean seasonally.

### B-Cooling Start-Up

*NOTE-The following is a generalized procedure and does not apply to all thermostat control systems. Electronic thermostat control systems may operate differently.*

- 1- Set fan switch to AUTO or ON and move the system selection switch to COOL. Adjust the thermostat to a setting far enough below room temperature to bring on the compressor. Compressor will start and cycle on demand from the thermostat. After a 30 second time delay (approximate) the indoor blower will energize.
- 2- The refrigerant circuit is charged with HCFC-22 or HFC-410A refrigerant. See condensing unit rating plate for correct charge amount.
- 3- Refer to the correct condensing unit service manual for more information.

### C-Heating Start-Up

- 1- Set the fan switch to AUTO or ON and move the system selection switch to HEAT. Adjust the thermostat setting above room temperature.
- 2- The indoor blower and the electric heat will stage on based on sequencer timing.

### D-Safety or Emergency Shutdown

Turn off unit power at circuit breaker.

### E-Extended Period Shutdown

Turn off thermostat or set to UNOCCUPIED mode. Turn off power to unit. All access panels and covers must be in place

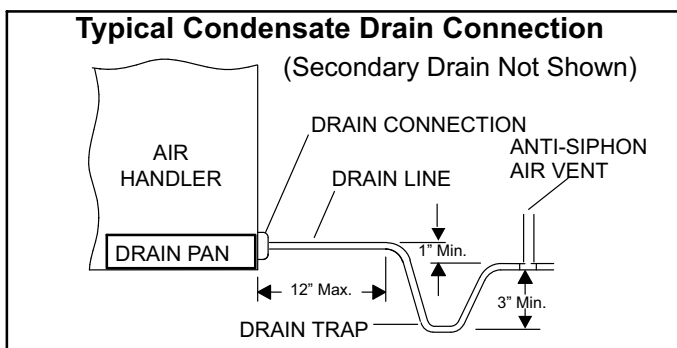

**FIGURE 13**

*NOTE - Horizontal runs over 15 ft. long must also have an antisiphon air vent (standpipe) installed ahead of the horizontal run (See figure 13). An extremely long horizontal run may require an oversized drain line to eliminate air trapping.*

*NOTE - Do not operate air handler without a drain trap. The condensate drain is on the negative pressure side of the blower; therefore, air being pulled through the condensate line will prevent positive drainage without a proper trap.*

and secured. The condensate assembly should be clean and dry for extended period shutdown.

## VI-TYPICAL OPERATING CHARACTERISTICS

### A-Blower Operation and Adjustment

*NOTE- The following is a generalized procedure and does not apply to all thermostat controls.*

- 1- Blower operation is dependent on thermostat control system.
- 2- Generally, blower operation is set at thermostat subbase fan switch. With fan switch in ON position, blower operates continuously. With fan switch in AUTO position, blower cycles with demand.
- 3- In all cases, blower and entire unit will be off when the system switch is in OFF position.

### B-External Static Pressure

- 1- Measure tap locations as shown in figure 14.

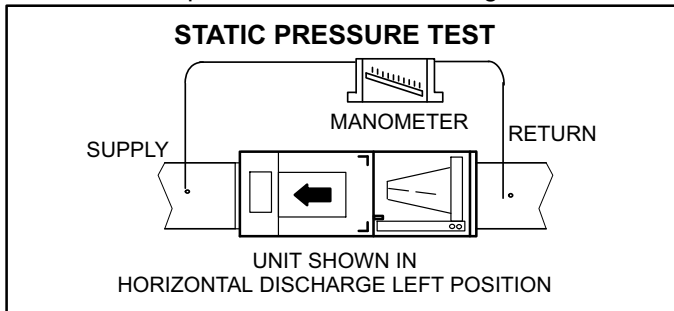

**FIGURE 14**

- 2- Punch a 1/4" (6mm) diameter hole in supply and return air plenums. Insert manometer hose flush with inside edge of hole or insulation. Seal around the hose with permagum. Connect the zero end of the manometer to the discharge (supply) side of the system. On ducted systems, connect the other end of manometer to the return duct as above. For systems with non-ducted returns, leave the other end of the manometer open to the atmosphere.
- 3- With only the blower motor running and the evaporator coil dry, observe the manometer reading. Adjust blower motor speed to deliver the air desired according to the job requirements.
- 4- For best air performance external static pressure drop must not exceed 0.5" W.C. (1.2 kPa). Refer to blower data tables for cfm and external static.
- 5- Seal around the hole when the check is complete.

### C-Blower Speed Taps

#### Change Blower Speed

**WARNING**

**Electric shock hazard! - Disconnect all power supplies before servicing.**

**Replace all parts and panels before operating.**

**Failure to do so can result in death or electrical shock.**

1. Disconnect all power supplies.
2. Remove the air handler access panel.
3. Locate pin number 2 on the blower relay. Two black wires are connected to this terminal pin. One connects to pin number 5 on the blower relay, one connects to an inline splice connecting to a red or blue wire.
4. Remove the wire going to the 4-pin blower motor connector from the splice.
5. Connect the blower lead [Red (LO), Black (HI)] onto the splice from the 4-pin blower motor connector.

*NOTE - Unused blower speed taps are factory-covered with plastic caps. Remove this cap from the desired blower speed tap and replace it over the factory-set blower tap.*

6. Replace all panels.
7. Reconnect power.

## VII-MAINTENANCE

**WARNING**

**Disconnect power before performing any maintenance.**

At the beginning of each heating/cooling season, the system should be checked as follows:

### A-Filters

*NOTE- Filter access panel must be in place during unit operation, or excessive warm air may enter the unit resulting in water blow-off problems.*

**TABLE 7**

Unit Air Filter Size Chart	
Model	Filter Size
18 / 24	16" x 20"
30 / 36	18" x 20"
42 / 48 / 60	18" x 25"

To remove filter, remove 1/4" head screws holding the filter panel in place. Slide filter out of the guides on either side of cabinet, insert new filter and replace panel. Filters should be inspected monthly and must be replaced when dirty to ensure proper blower coil operation. See table 7 for replacement filter sizes.

### B-Supply Air Blower

- 1- Check and clean blower wheel.
- 2- Motors are prelubricated for extended life; no further lubrication is required.

### C-Electrical

- 1- Check all wiring for loose connections.
- 2- Check circuit breaker located in unit control box.
- 3- Check for correct voltage at unit (unit operating).
- 4- Check amp-draw on blower motor.
- 5- Check to see that heat (if applicable) is operating.

# VIII-WIRING DIAGRAMS AND SEQUENCE OF OPERATIONS

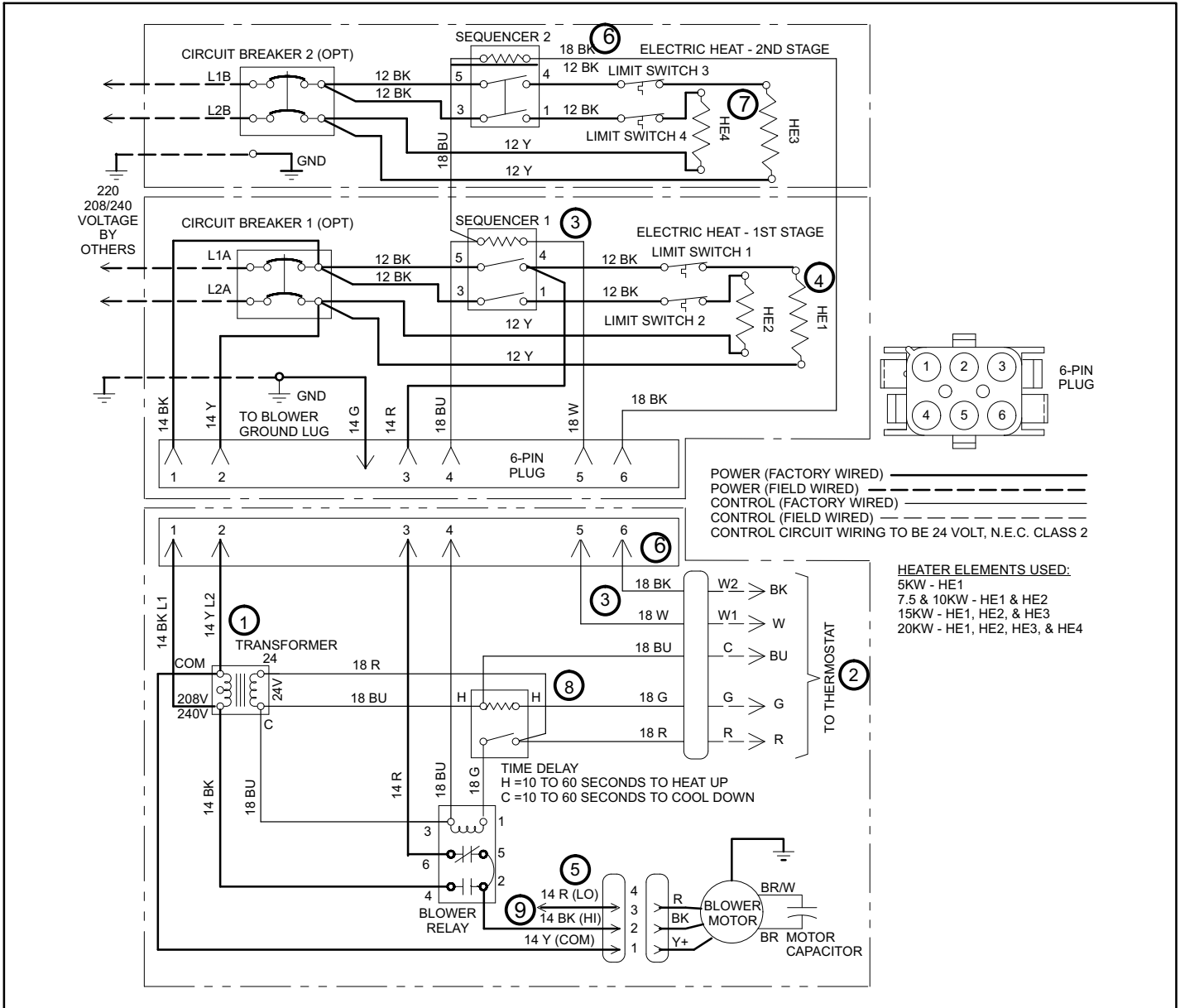

Figure 15. Wiring Diagram — CB(X)26UH-0XX-(R)-230-01 and CB(X)26UH-0XX-(R)-230-02 Builds

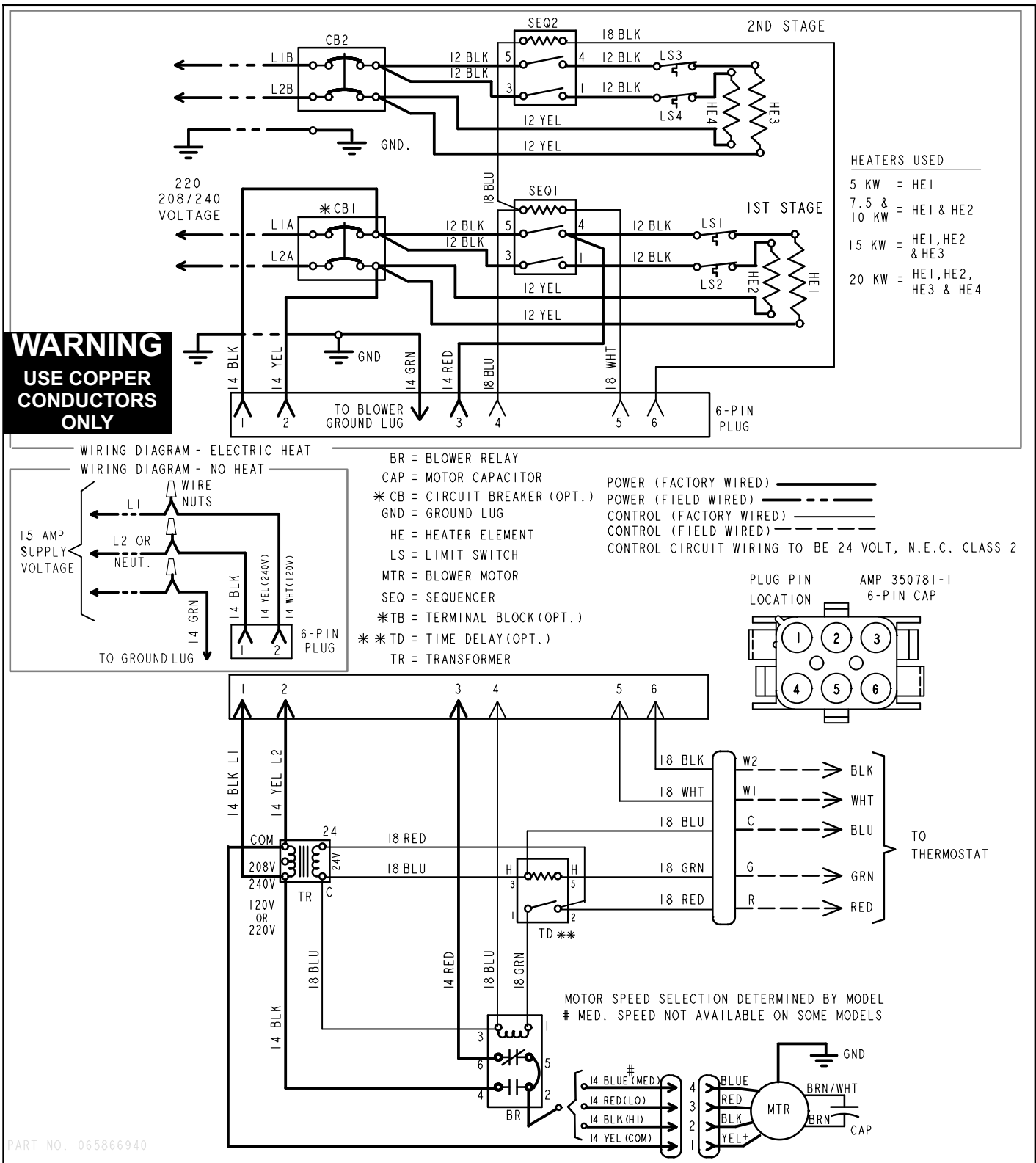

Figure 16. Wiring Diagram — Applicable to units with a three speed motor with date of manufacture date code of January 2009 through January 2010:

## **A-ECB26UH & ECBX26UH - SEQUENCE OF OPERATION**

### **FIRST STAGE HEAT**

- 1- Line voltage is routed to transformer and blower relay.
- 2- 24VAC is supplied to indoor thermostat and electric heat, if used.
- 3- When there is a call for heat W1 of the thermostat energizes sequencer relay 1.
- 4- Assuming limit switch 1 and 2 are closed, sequencer relay 1 energizes HE1 and HE2.
- 5- Indoor blower is energized on heating speed, after sequencer timing is complete.

### **SECOND STAGE HEAT**

- 6- W2 in the thermostat energizes sequencer relay 2.
- 7- Assuming limit switch 3 and 4 are closed sequencer relay energizes HE3 and HE4.

### **COOLING**

- 8- When there is a call for cooling, G of the thermostat energizes blower time delay relay.
- 9- After a 30 second delay (approximate) blower relay energizes blower motor on cooling speed. *Blower will also delay 30 seconds after cool demand is satisfied.*